



Season Actuals 2016

Prepared for: Platinum Precision
Farms

Date: December 12, 2018

Printed by: Connor Lankford

Company: Valley Agronomics



Index

Area Summary	3
Input Summary	4
Profit by Crop	7
Profit by Farm	11
Profit by Field	15
Profit by Season	25

- AF Reservoir
- Reservoir 1
- Reservoir 2
- Reservoir 3
- Reservoir 4
- Grandview
- Grandview 1
- Grandview 2
- Grandview 3
- Grandview 4
- Grandview 5
- Highway 39
- Highway 1
- Highway 2
- Highway 3
- Springfield
- Springfield 1
- Springfield 2
- Springfield 3
- Springfield 4
- Springfield 5
- Springfield 6

Area Summary

GROUP	CROP	VARIETY	AREA (acre)	(%)
Cereals	Wheat - winter	Brundage 96	526.56	28.84
		CROP TOTAL	526.56	28.84
		GROUP TOTAL	526.56	28.84
Pasture	Alfalfa	LegenDairy XHD	115.60	6.33
		CROP TOTAL	115.60	6.33
		GROUP TOTAL	115.60	6.33
Sugar Crops	Sugar Beet	BTS 20RR28	598.64	32.78
		Crystal A399NT	71.53	3.92
		CROP TOTAL	670.17	36.70
		GROUP TOTAL	670.17	36.70
Vegetables & Melons	Potato	Russet Burbank	513.66	28.13
		CROP TOTAL	513.66	28.13
		GROUP TOTAL	513.66	28.13
		GRAND TOTAL	1825.99	100.00

Input Summary

INPUTS	AMOUNT	AVERAGE UNIT COST	TOTAL COST
Seeds			
Alturas (wheat)	4904.40 lbs	\$0.10 /lbs	\$490.44
BTS 20RR28	83809.60 lbs	\$0.50 /lbs	\$41,904.80
Brundage 96	67987.20 lbs	\$0.08 /lbs	\$5,724.54
Crystal A399NT	10014.20 lbs	\$0.53 /lbs	\$5,307.53
Russet Burbank	14382.48 lbs	\$0.09 /lbs	\$1,294.42
		TOTAL	\$54,721.73
Operations			
Boomspray - contract	513.66 acre	\$12.00 /acre	\$6,163.92
Boomspray application	3703.78 acre	\$7.83 /acre	\$29,009.44
Deep Ripping	513.66 acre	\$40.00 /acre	\$20,546.40
Fertilizer Application	1640.87 acre	\$9.95 /acre	\$16,326.96
Field Scouting	118.47 acre	\$0.75 /acre	\$88.85
Harvest	1710.39 acre	\$35.99 /acre	\$61,561.02
Irrigation	1603.20 acre	\$13.36 /acre	\$21,415.20
Mechanical harvesting	80.87 acre	\$10.00 /acre	\$808.70
Planting	1791.26 acre	\$17.97 /acre	\$32,187.21
Seed - Treatment	513.66 acre	\$1.00 /acre	\$513.66
Spray/aerial	1750.39 acre	\$9.35 /acre	\$16,370.78
Spray/herbicide	606.56 acre	\$10.00 /acre	\$6,065.60
Spreading fertilizer	606.56 acre	\$10.00 /acre	\$6,065.60
Variable Rate Ground - spreading 1	1027.32 acre	\$12.00 /acre	\$12,327.84
		TOTAL	\$229,451.18
Acidifiers			
Aduro	25.68 gal	\$22.00 /gal	\$565.03
		TOTAL	\$565.03
Adjuvants			
Masterlock	55.49 gal	\$26.13 /gal	\$1,450.13
		TOTAL	\$1,450.13
Deposition Aids			
InterLock	45.50 gal	\$66.00 /gal	\$3,002.88
		TOTAL	\$3,002.88
Fertilizers			
Actagro Katalyst 0-0-25	115.60 gal	\$15.00 /gal	\$1,734.00
Actagro Liquid Humus 0-0-4	285.73 gal	\$28.67 /gal	\$8,191.78
Actagro Structure 7-21-0	3826.82 gal	\$8.00 /gal	\$30,614.56
Agfinity Manganese Sulfate 32%	3210.38 lbs	\$0.74 /lbs	\$2,369.26
Agrium 11-52-0 MAP	62759.84 lbs	\$0.20 /lbs	\$12,679.48
Andersons 46-0-0	146452.84 lbs	\$0.18 /lbs	\$26,112.61
Elemental Sulphur 85%	60098.22 lbs	\$0.23 /lbs	\$14,062.98
K-Mag	47770.38 lbs	\$0.27 /lbs	\$13,069.98
Muriate of Potash 0-0-60	54311.04 lbs	\$0.20 /lbs	\$10,862.21

INPUTS	AMOUNT	AVERAGE UNIT COST	TOTAL COST
Power Zinc 35 Granular	7191.24 lbs	\$0.57 /lbs	\$4,073.12
Power-Line Urea 46-0-0 Granular	8720.00 lbs	\$0.18 /lbs	\$1,569.60
Simplot Monoammonium Phosphate 11-52-0	3840.00 lbs	\$0.20 /lbs	\$768.00
Sulfuric Acid	15409.80 gal	\$0.90 /gal	\$13,868.82
Thio-Sul (12-0-0-26S)	9322.93 gal	\$2.25 /gal	\$20,965.96
Valley 0-0-60	77049.00 lbs	\$0.17 /lbs	\$13,314.07
Valley 12-45-0-5-1Z	155125.32 lbs	\$0.27 /lbs	\$42,256.14
Valley 21-0-0-24s	195190.80 lbs	\$0.15 /lbs	\$29,512.85
Valley Agronomics 11-37-0	6677.58 gal	\$4.11 /gal	\$27,412.80
Valley Agronomics 32-0-0	41149.55 gal	\$2.50 /gal	\$102,992.30
Winfield Liquid Zinc 7%	64.21 gal	\$6.00 /gal	\$385.24
		TOTAL	\$376,815.77
Fungicides			
DuPont Aproach Fungicide	18.96 gal	\$160.00 /gal	\$3,032.80
Endura Fungicide	192.62 lbs	\$89.60 /lbs	\$17,258.98
Luna Tranquility	50.81 gal	\$347.50 /gal	\$17,657.06
Moncut 70-DF	385.25 lbs	\$36.00 /lbs	\$13,868.82
Topaz	38.65 gal	\$73.55 /gal	\$2,842.44
UPI Manzate Pro Stick	513.66 lbs	\$5.70 /lbs	\$2,927.86
UPI Microthiol Disperss	1340.34 lbs	\$3.73 /lbs	\$4,999.47
Zing!	128.42 gal	\$70.00 /gal	\$8,989.05
		TOTAL	\$71,576.48
Herbicides			
Boundary 6.5 EC Herbicide	128.42 gal	\$90.00 /gal	\$11,557.35
Dimetric DF 75%	169.51 lbs	\$13.00 /lbs	\$2,203.60
Huskie Herbicide	71.08 gal	\$80.00 /gal	\$5,686.50
Parazone 3SL	64.21 gal	\$30.00 /gal	\$1,926.22
Prowl H2O Herbicide	96.31 gal	\$48.00 /gal	\$4,622.94
Reglone Desiccant	128.42 gal	\$93.00 /gal	\$11,942.60
Roundup PowerMAX Herbicide	322.10 gal	\$26.00 /gal	\$8,374.58
		TOTAL	\$46,313.80
Insecticides			
ABBA Ultra	32.10 gal	\$105.00 /gal	\$3,370.89
Advise Four Flowable Insecticide	0.00 gal	\$0.00 /gal	\$0.00
Arysta Chlorpyrifos 4E AG	125.66 gal	\$61.00 /gal	\$7,665.07
Stallion EC Insecticide	44.50 gal	\$100.00 /gal	\$4,450.35
		TOTAL	\$15,486.31
Plant Growth Regulators			
MANA Ethephon 2SL	106.23 gal	\$80.00 /gal	\$8,498.40
		TOTAL	\$8,498.40
Seed Treatment Fungicides			
Power-Line Potato Seed Treat Mancozeb 6% Plus Bark	0.00 lbs	\$0.00 /lbs	\$0.00
		TOTAL	\$0.00
Soil Fumigants			
Vapam HL Soil Fumigant	20546.40 gal	\$6.00 /gal	\$123,278.40

INPUTS	AMOUNT	AVERAGE UNIT COST	TOTAL COST
			TOTAL \$123,278.40
<hr/>			
Water Conditioning Agents			
Class Act NG	217.39 gal	\$16.09 /gal	\$3,498.40
			TOTAL \$3,498.40
			TOTAL\$934,658.49

Crop

Year	Fields	Area (acre)	Yield	Price (\$/acre)	Other Inc. (\$/acre)	Total Inc. (\$/acre)	Seed Cost (\$/acre)	Fert Cost (\$/acre)	Chem Cost (\$/acre)	Cont Cost (\$/acre)	Oper Cost (\$/acre)	Other Cost (\$/acre)	Total Cost (\$/acre)	Profit (\$/acre)
Alfalfa (yield in ton/acre)														
2016	2	115.6	5.97	376	0	376	0	74	15	0	16	0	105	271
CROP TOTAL		115.6			0	376	0	74	15	0	16	0	105	271
Potato (yield in ton/acre)														
2016	5	513.66	23.12	2080	0	2,080	2	554	430	0	209	0	1,196	885
CROP TOTAL		513.66			0	2,080	2	554	430	0	209	0	1,196	885
Sugar Beet (yield in ton/acre)														
2016	5	670.17	39.46	1578	0	1,578	70	47	47	0	114	0	278	1,300
CROP TOTAL		670.17			0	1,578	70	47	47	0	114	0	278	1,300
Wheat - winter (yield in bu/acre)														
2016	6	526.56	124.6	479	0	479	12	99	38	0	84	0	232	247
CROP TOTAL		526.56			0	479	12	99	38	0	84	0	232	247
GRAND TOTAL					0	1,327	30	206	150	0	126	0	512	815

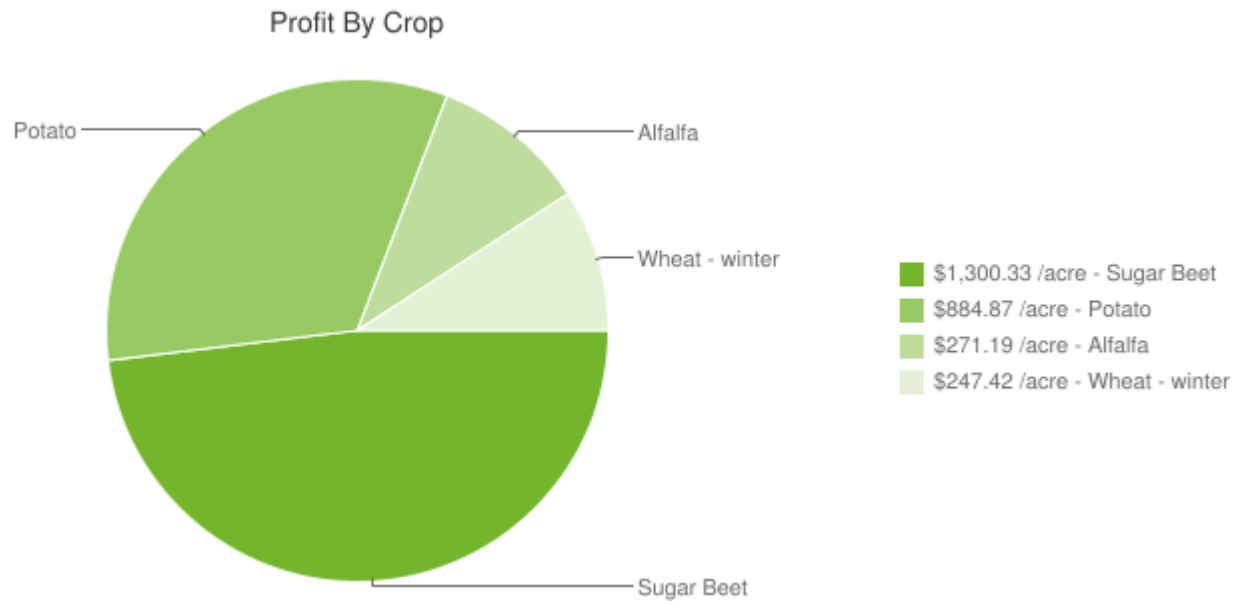

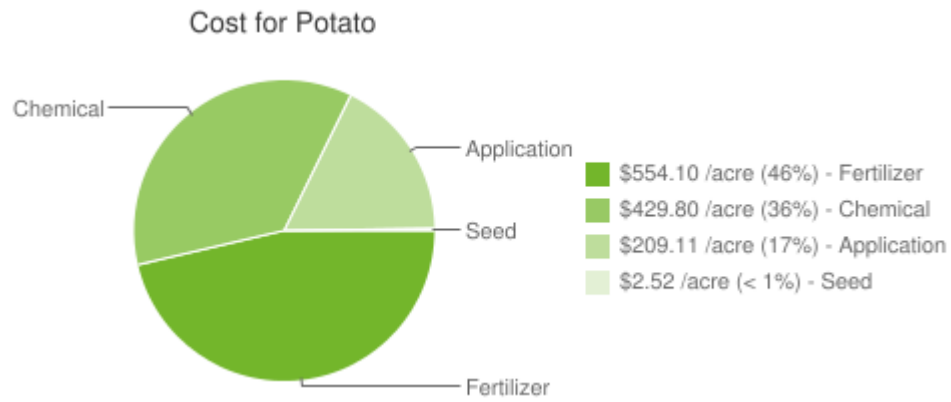
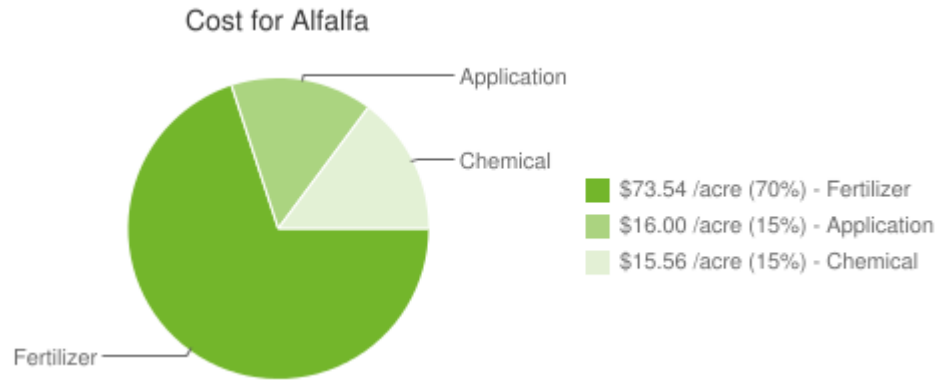

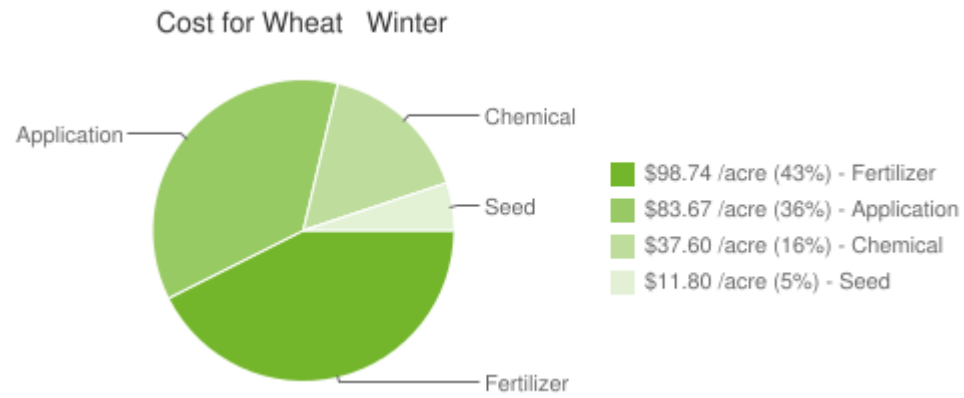
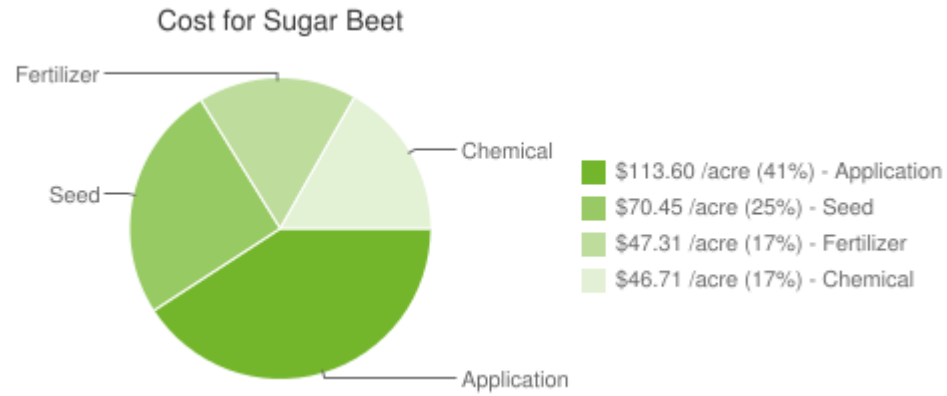

Farm

Year	Area (acre)	Other Inc. (\$/acre)	Total Inc. (\$/acre)	Seed Cost (\$/acre)	Fert Cost (\$/acre)	Chem Cost (\$/acre)	Cont Cost (\$/acre)	Oper Cost (\$/acre)	Other Cost (\$/acre)	Total Cost (\$/acre)	Profit (\$/acre)
AF Reservoir											
	320.52	0	2,342	5	523	387	0	247	0	1,161	1,181
FARM TOTAL	320.52	0	2,342	5	523	387	0	247	0	1,161	1,181
Grandview											
	489.16	0	873	9	158	97	0	74	0	339	534
FARM TOTAL	489.16	0	873	9	158	97	0	74	0	339	534
Highway 39											
	355.04	0	1,202	41	274	215	0	157	0	687	515
FARM TOTAL	355.04	0	1,202	41	274	215	0	157	0	687	515
Springfield											
	661.27	0	1,237	51	52	40	0	88	0	231	1,005
FARM TOTAL	661.27	0	1,237	51	52	40	0	88	0	231	1,005
GRAND TOTAL	1825.99	0	1,327	30	206	150	0	126	0	512	815

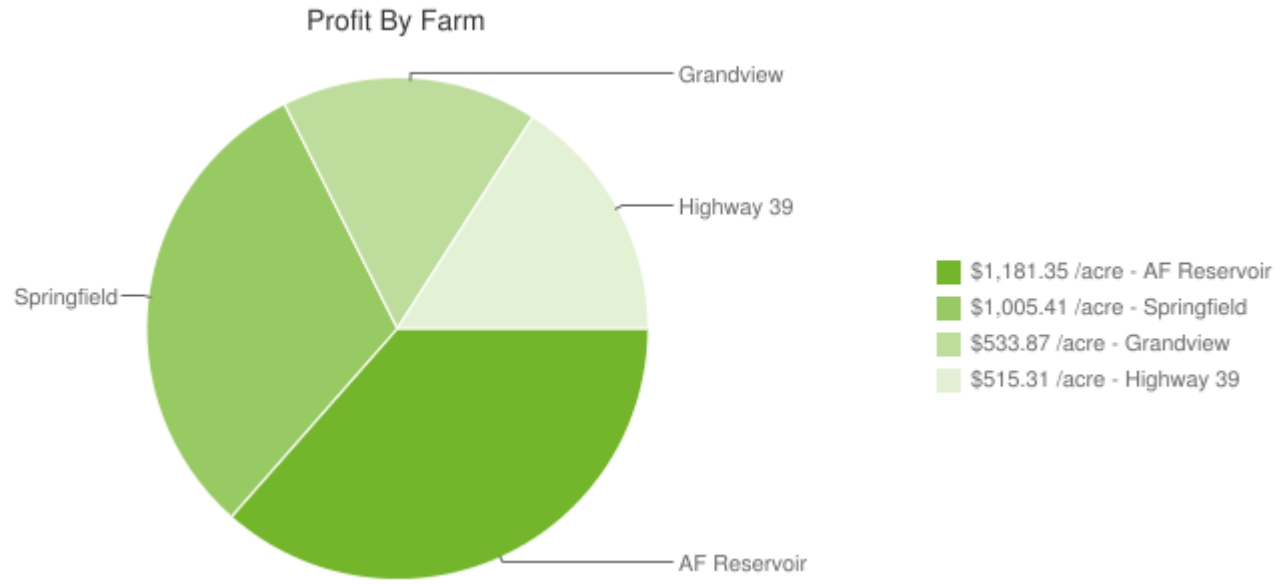

Cost for Af Reservoir

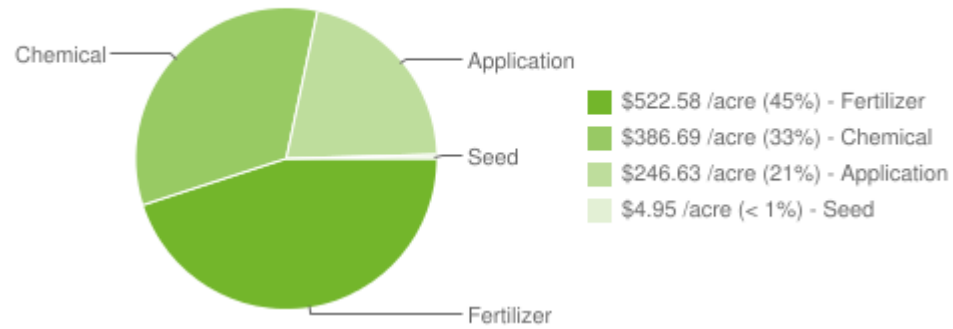

Cost for Grandview

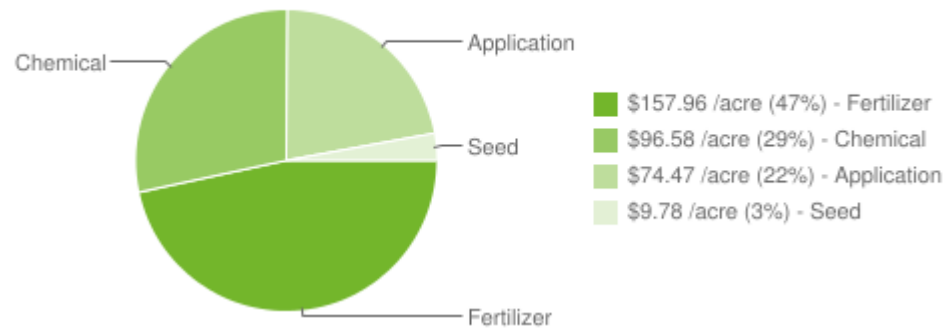

Cost for Highway 39

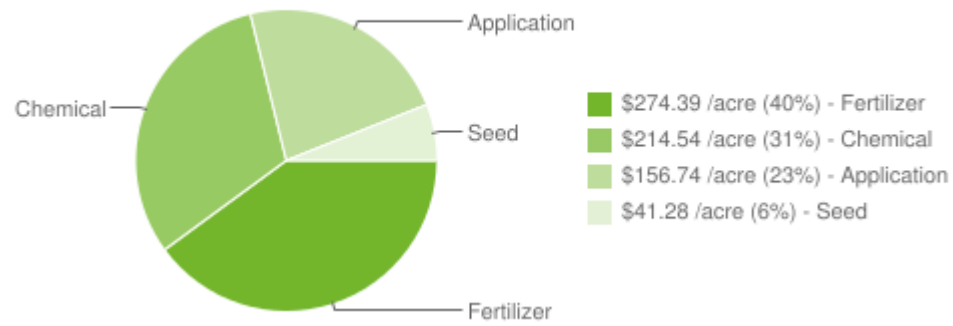

Cost for Springfield

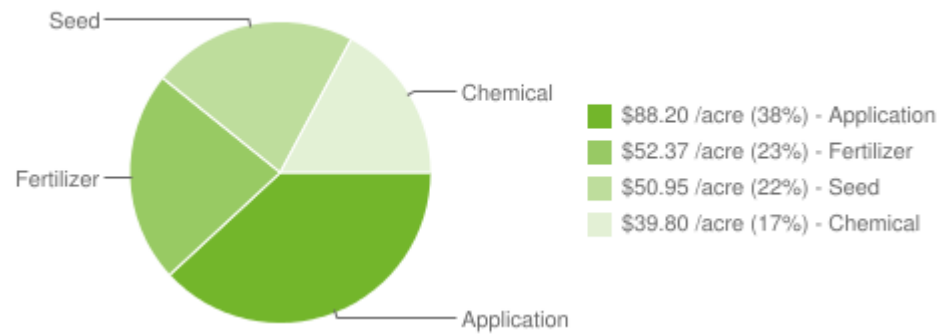

Field

Year	Crop/Var	Area (acre)	Yield	Price (\$/acre)	Other Inc. (\$/acre)	Total Inc. (\$/acre)	Seed Cost (\$/acre)	Fert Cost (\$/acre)	Chem Cost (\$/acre)	Cont Cost (\$/acre)	Oper Cost (\$/acre)	Other Cost (\$/acre)	Total Cost (\$/acre)	Profit (\$/acre)
AF Reservoir														
Reservoir 1														
2016	Potato - Russet Burbank (ton/acre)	59	20	2400	0	2,400	2	554	430	0	209	0	1,195	1,205
FARM TOTAL		59	20	2400	0	2,400	2	554	430	0	209	0	1,195	1,205
Reservoir 2														
2016	Potato - Russet Burbank (ton/acre)	85.02	23.99	2879	0	2,879	2	554	430	0	209	0	1,195	1,684
FARM TOTAL		85.02	23.99	2879	0	2,879	2	554	430	0	209	0	1,195	1,684
Reservoir 3														
2016	Potato - Russet Burbank (ton/acre)	136.5	20.92	2511	0	2,511	2	554	430	0	209	0	1,195	1,315
FARM TOTAL		136.5	20.92	2511	0	2,511	2	554	430	0	209	0	1,195	1,315
Reservoir 4														
2016	Wheat - winter - Brundage 96 (bu/acre)	40	120	540	0	540	22	302	84	0	511	0	918	-378
FARM TOTAL		40	3.6	540	0	540	22	302	84	0	511	0	918	-378
FARM TOTAL		320.52	19.41	2342	0	2,342	5	523	387	0	247	0	1,161	1,181
Grandview														
Grandview 1														
2016	Wheat - winter - Brundage 96 (bu/acre)	98.96	123.79	464	0	464	10	75	34	0	47	0	166	299
FARM TOTAL		98.96	3.71	464	0	464	10	75	34	0	47	0	166	299
Grandview 2														
2016	Wheat - winter - Brundage 96 (bu/acre)	48.36	119.11	447	0	447	10	75	34	0	47	0	166	281
FARM TOTAL		48.36	3.57	447	0	447	10	75	34	0	47	0	166	281
Grandview 3														
2016	Potato - Russet Burbank (ton/acre)	77.6	24.81	2977	0	2,977	2	554	430	0	210	0	1,196	1,781
FARM TOTAL		77.6	24.81	2977	0	2,977	2	554	430	0	210	0	1,196	1,781
Grandview 4														
2016	Wheat - winter - Brundage 96 (bu/acre)	40.87	110.35	480	0	480	22	154	34	0	71	0	281	199
FARM TOTAL		40.87	3.31	480	0	480	22	154	34	0	71	0	281	199
Grandview 5														
2016	Wheat - winter - Brundage 96 (bu/acre)	223.37	129.78	487	0	487	10	75	34	0	47	0	166	321
FARM TOTAL		223.37	3.89	487	0	487	10	75	34	0	47	0	166	321

Year	Crop/Var	Area (acre)	Yield	Price (\$/acre)	Other Inc. (\$/acre)	Total Inc. (\$/acre)	Seed Cost (\$/acre)	Fert Cost (\$/acre)	Chem Cost (\$/acre)	Cont Cost (\$/acre)	Oper Cost (\$/acre)	Other Cost (\$/acre)	Total Cost (\$/acre)	Profit (\$/acre)
FARM TOTAL		489.16	7.09	873	0	873	9	158	97	0	74	0	339	534
Highway 39														
Highway 1														
2016	Sugar Beet - BTS 20RR28 (RR) (ton/acre)	127.97	40	1600	0	1,600	70	56	47	0	116	0	289	1,311
FARM TOTAL		127.97	40	1600	0	1,600	70	56	47	0	116	0	289	1,311
Highway 2														
2016	Sugar Beet - Crystal A399NT (ton/acre)	71.53	39.7	1588	0	1,588	74	56	47	0	116	0	293	1,295
FARM TOTAL		71.53	39.7	1588	0	1,588	74	56	47	0	116	0	293	1,295
Highway 3														
2016	Potato - Russet Burbank (ton/acre)	155.54	24.91	698	0	698	2	554	430	0	209	0	1,195	-498
FARM TOTAL		155.54	24.91	698	0	698	2	554	430	0	209	0	1,195	-498
FARM TOTAL		355.04	33.33	1202	0	1,202	41	274	215	0	157	0	687	515
Springfield														
Springfield 1														
2016	Sugar Beet - BTS 20RR28 (RR) (ton/acre)	236.94	38.85	1554	0	1,554	70	56	47	0	116	0	289	1,265
FARM TOTAL		236.94	38.85	1554	0	1,554	70	56	47	0	116	0	289	1,265
Springfield 2														
2016	Wheat - winter - Brundage 96 (bu/acre)	75	124	465	0	465	10	75	34	0	47	0	166	299
FARM TOTAL		75	3.72	465	0	465	10	75	34	0	47	0	166	299
Springfield 3														
2016	Sugar Beet - BTS 20RR28 (RR) (ton/acre)	126.54	37.84	1514	0	1,514	70	56	47	0	116	0	289	1,224
FARM TOTAL		126.54	37.84	1514	0	1,514	70	56	47	0	116	0	289	1,224
Springfield 4														
2016	Sugar Beet - BTS 20RR28 (RR) (ton/acre)	107.19	41.93	1677	0	1,677	70	0	47	0	101	0	218	1,459
FARM TOTAL		107.19	41.93	1677	0	1,677	70	0	47	0	101	0	218	1,459
Springfield 5														
2016	Alfalfa - LegenDairy XHD (ton/acre)	69.79	6.02	391	0	391	0	74	15	0	16	0	105	286
FARM TOTAL		69.79	6.02	391	0	391	0	74	15	0	16	0	105	286
Springfield 6														
2016	Alfalfa - LegenDairy XHD (ton/acre)	45.81	5.89	354	0	354	0	74	15	0	16	0	105	249
FARM TOTAL		45.81	5.89	354	0	354	0	74	15	0	16	0	105	249
FARM TOTAL		661.27	29.42	1237	0	1,237	51	52	40	0	88	0	231	1,005

Year	Crop/Var	Area (acre)	Yield	Price (\$/acre)	Other Inc. (\$/acre)	Total Inc. (\$/acre)	Seed Cost (\$/acre)	Fert Cost (\$/acre)	Chem Cost (\$/acre)	Cont Cost (\$/acre)	Oper Cost (\$/acre)	Other Cost (\$/acre)	Total Cost (\$/acre)	Profit (\$/acre)
GRAND TOTAL		1825.99			0	1,327	30	206	150	0	126	0	512	815

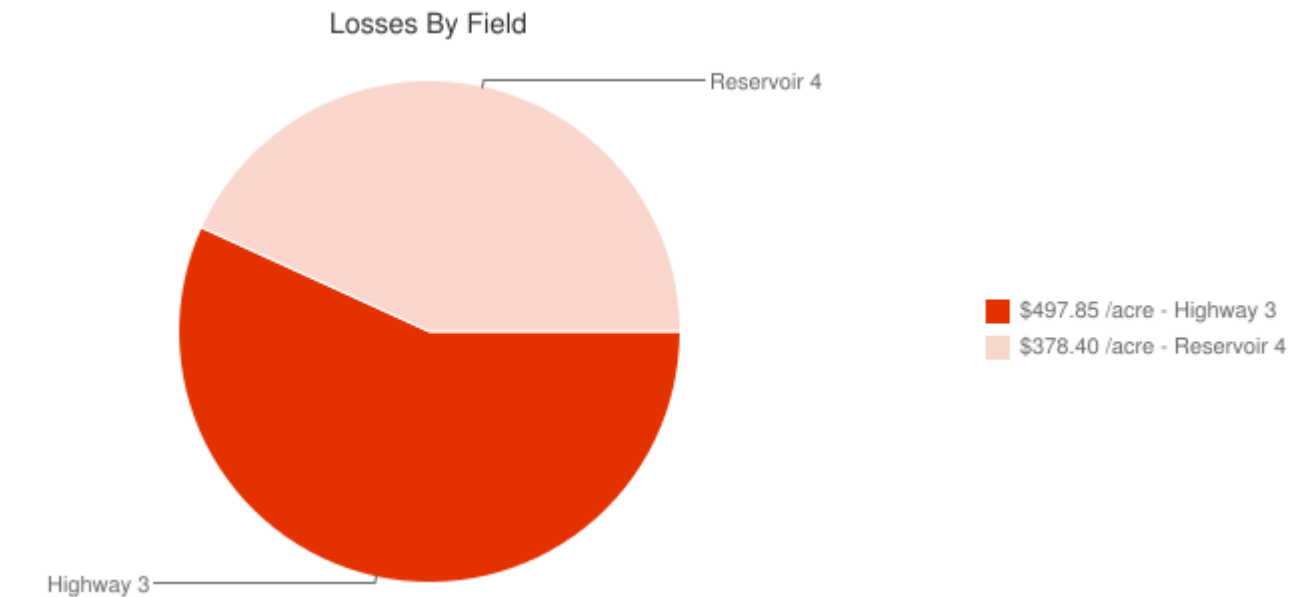
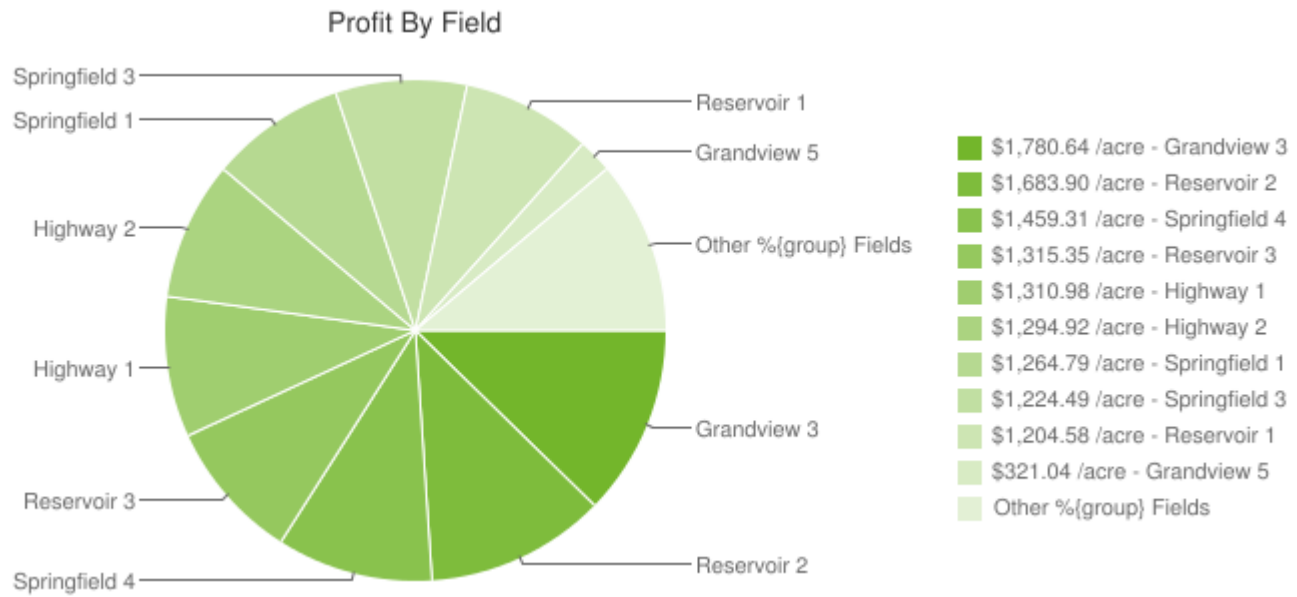

Cost for Reservoir 1

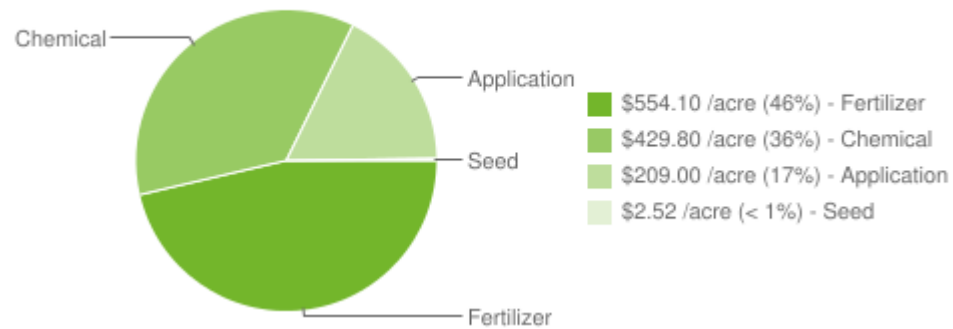

Cost for Reservoir 2

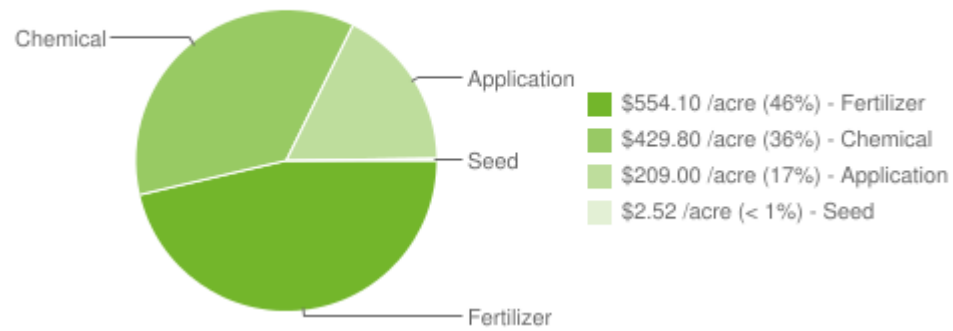

Cost for Reservoir 3

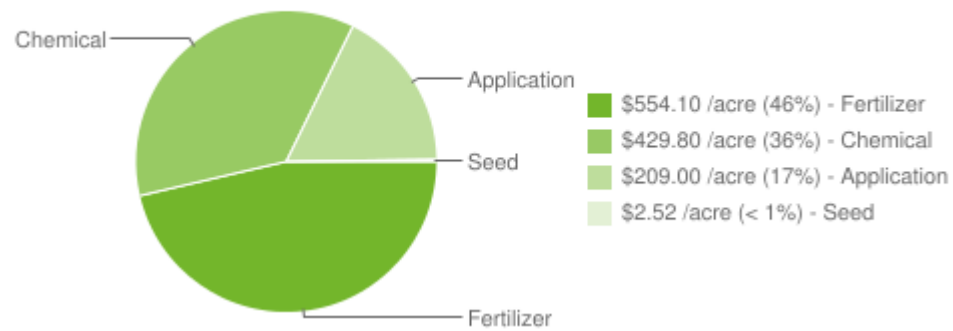

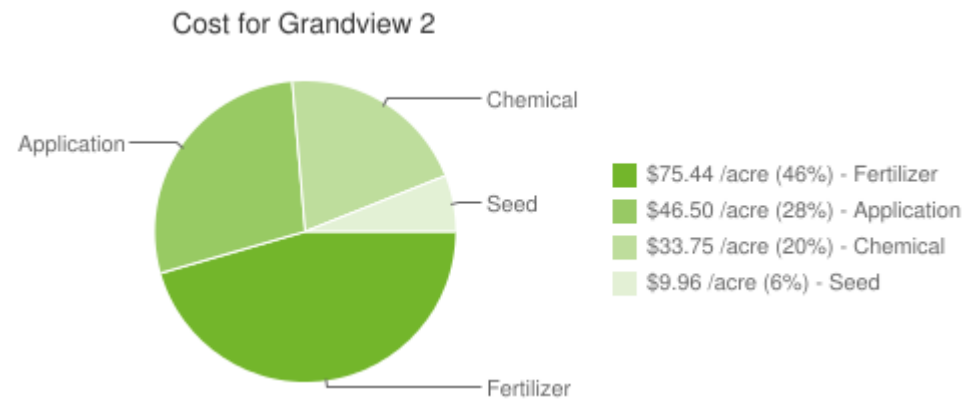
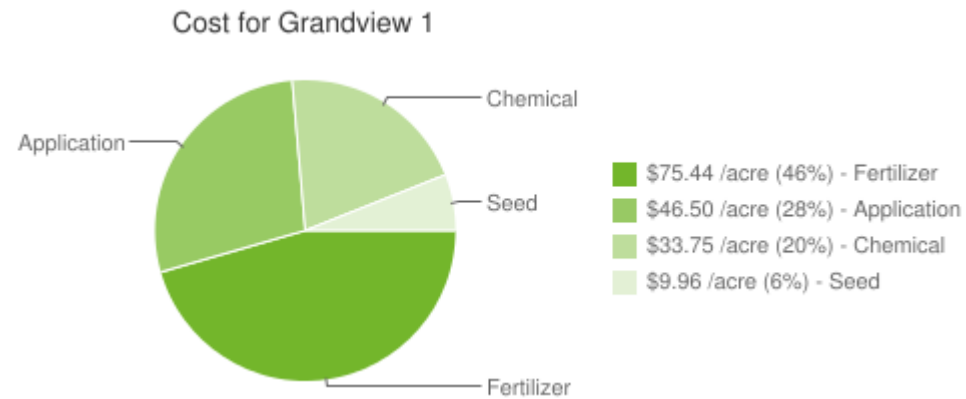
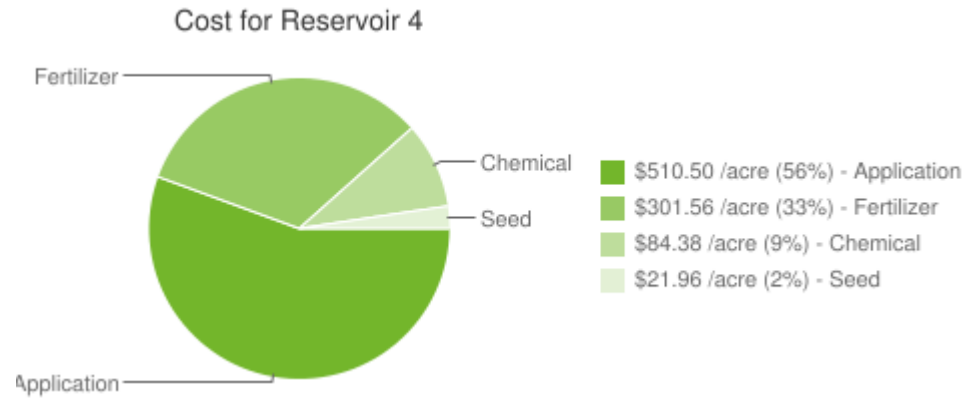

Cost for Grandview 3

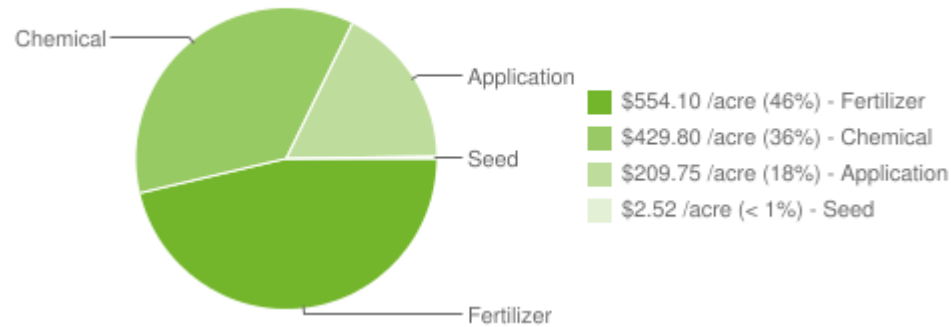

Cost for Grandview 4

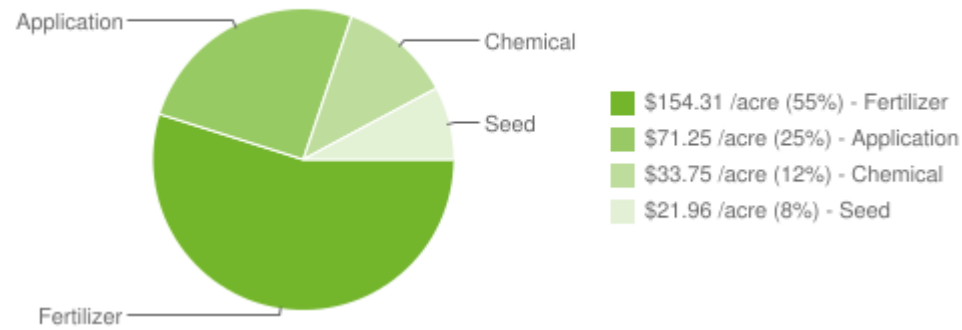

Cost for Grandview 5

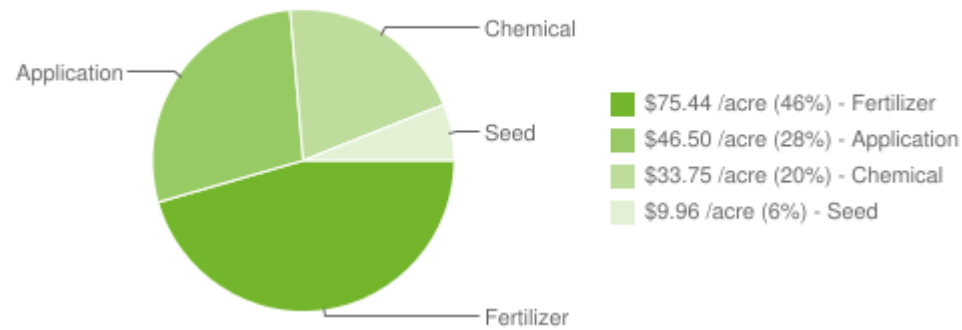

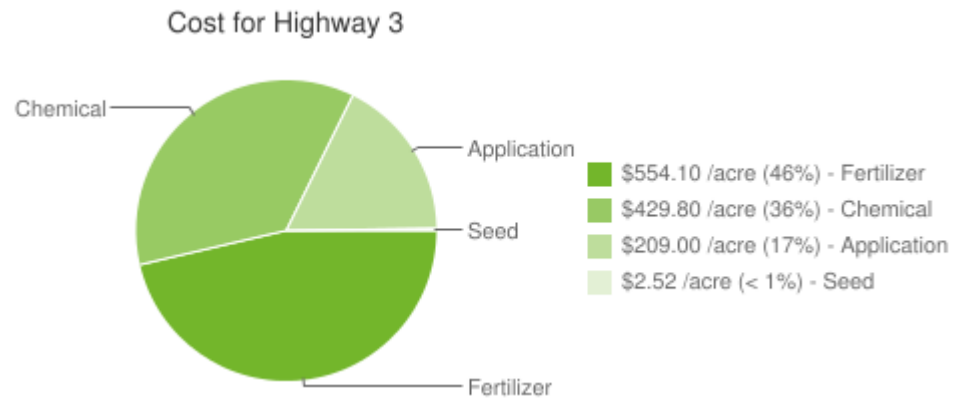
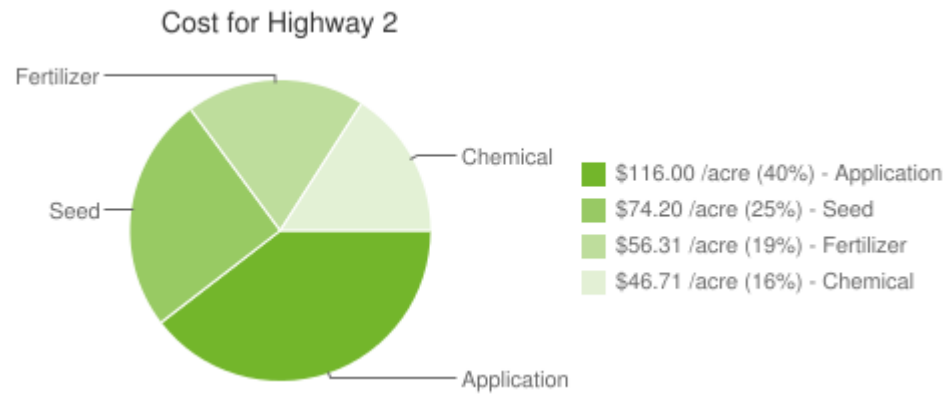
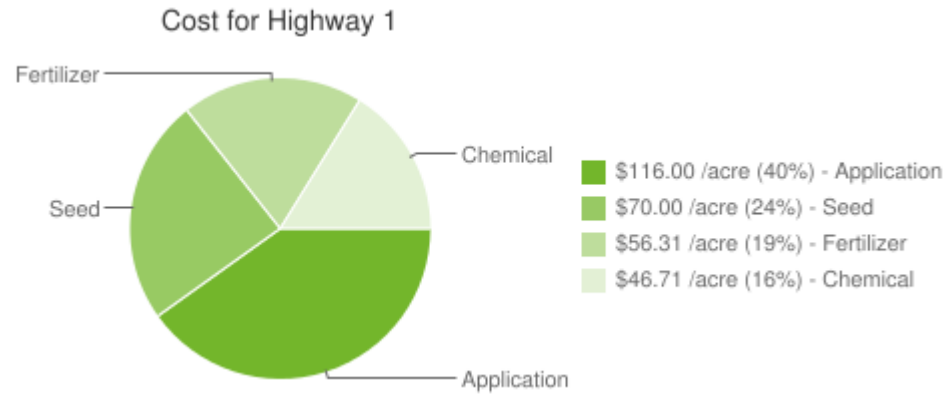

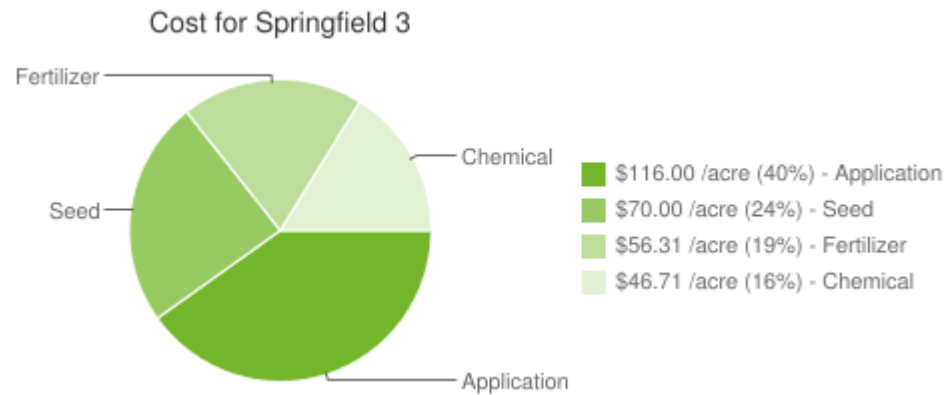
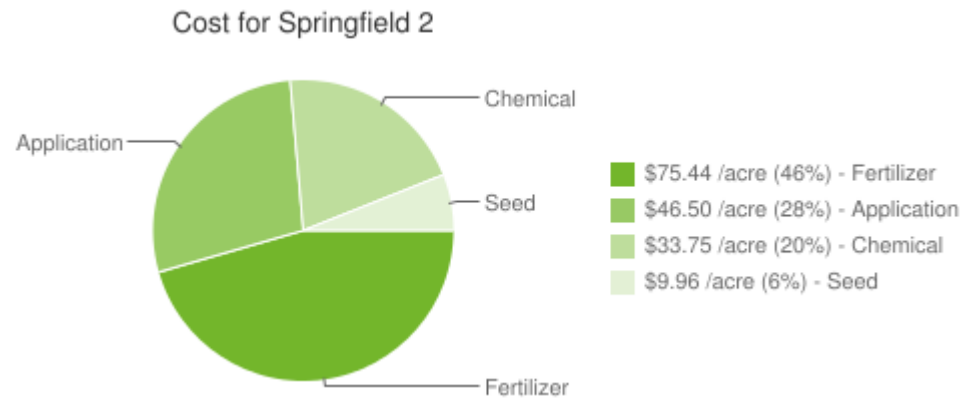
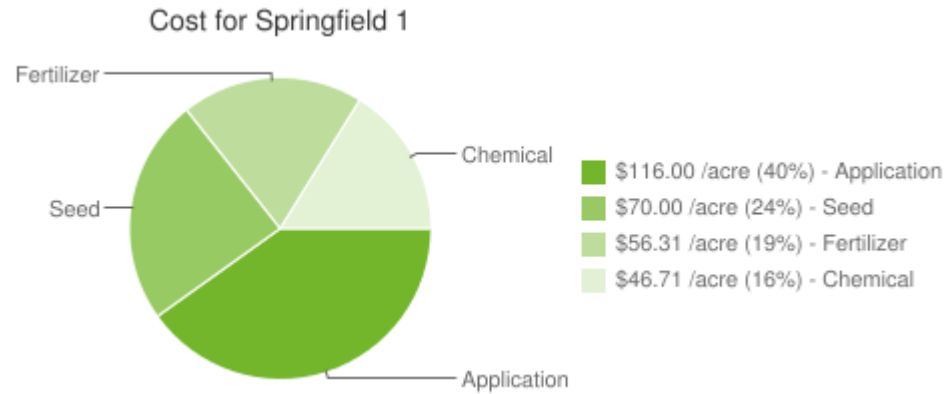

Cost for Springfield 4

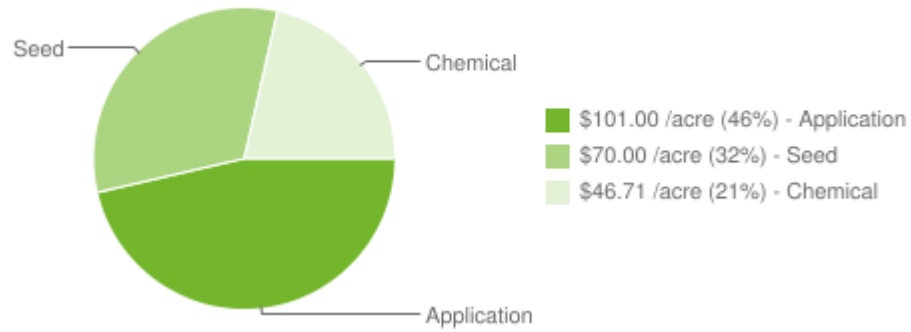

Cost for Springfield 5

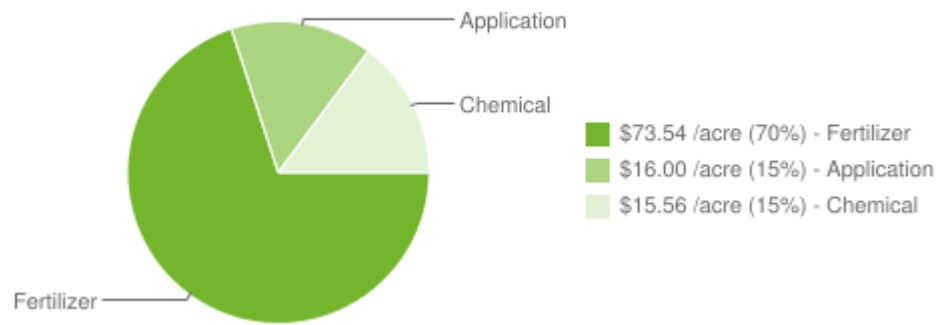

Cost for Springfield 6

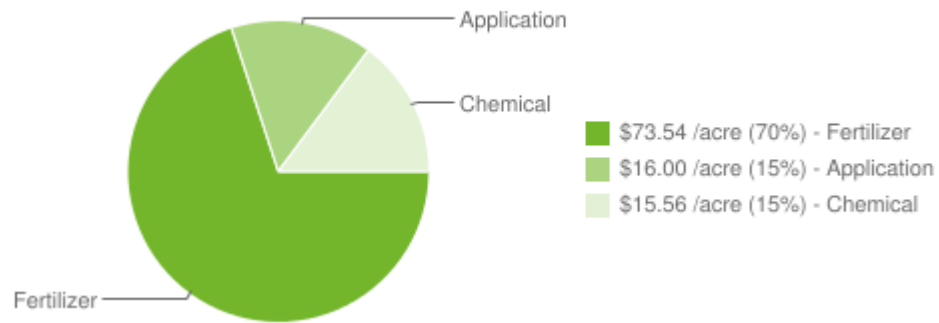

Season

Year	Area (acre)	Other Inc. (\$/acre)	Total Inc. (\$/acre)	Seed Cost (\$/acre)	Fert Cost (\$/acre)	Chem Cost (\$/acre)	Cont Cost (\$/acre)	Oper Cost (\$/acre)	Other Cost (\$/acre)	Total Cost (\$/acre)	Profit (\$/acre)
2016	1825.99	0	1,327	30	206	150	0	126	0	512	815
GRAND TOTAL	1825.99	0	1,327	30	206	150	0	126	0	512	815

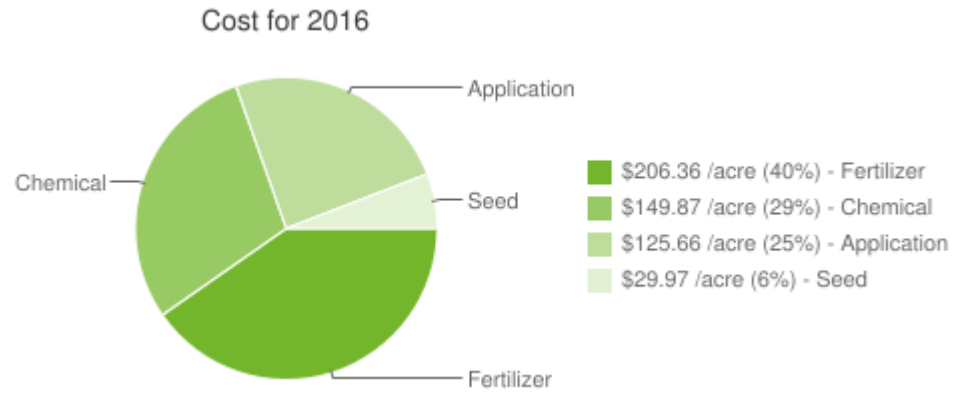

AF Reservoir Aerial Overview

Potato  Wheat - winter 

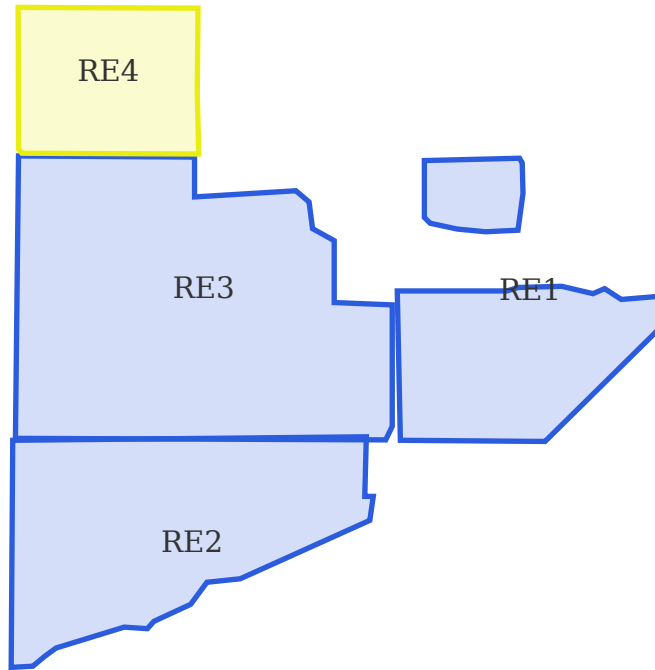

GROSS PROFIT BY ROTATION HISTORY - AF Reservoir

FIELD	2016
Reservoir 1 (Map : RE1)	Potato Russet Burbank \$1,204.58 /acre
Reservoir 2 (Map : RE2)	Potato Russet Burbank \$1,683.90 /acre
Reservoir 3 (Map : RE3)	Potato Russet Burbank \$1,315.35 /acre
Reservoir 4 (Map : RE4)	Wheat - winter Brundage 96 \$-378.40 /acre

Reservoir 1

FIELD SUMMARY

Costs	Income	Gross Profit	Gross Margin
\$1,195.42 /acre Total: \$70,529.65	\$2,400.00 /acre Total: \$141,600.00	\$1,204.58 /acre Total: \$71,070.35	50.19 %

INCOME SUMMARY

AREA	YIELD	PRICE	OTHER INCOME	TOTAL INCOME
59 acre	20 ton/acre	\$120.00 /ton	\$0.00	\$141,600.00

COST SUMMARY

SEED	FERTILIZER	CHEMICALS	CONTRACTORS	OPERATIONS	OTHER COSTS	TOTAL COST
\$2.52 /acre	\$554.10 /acre	\$429.80 /acre	\$0.00 /acre	\$209.00 /acre	\$0.00 /acre	\$1,195.42 /acre

ROTATION HISTORY

2016

Potato

59 acre | Russet Burbank

Active Ingredients: N 357.35 lbs/acre Phosphate 209.65 lbs/acre K2O 0.2 lbs/acre Potash 110.46 lbs/acre S 425.3 lbs/acre Mg 10.04 lbs/acre Mn 2 lbs/acre Zn 8.15 lbs/acre Organic acids including Humic and Fulvic 5.32 lbs/acre

ACTIVITIES

SITUATION/ TIMING	INPUTS	ACTIVE	APPLY	UNITS	COST / ACRE	COST
Potato Irrigation/ Fertigation 59 acre Oct 14, 2016 Fertigation	Irrigation		1 acre/acre	59 acre	\$15.00	\$885.00
	Valley Agronomics 32-0-0	Nitrogen	55 gal/acre	3,245 gal	\$137.66	\$8,121.84
	Thio-Sul (12-0-0-26S)	Sulfur and Nitrogen	18.15 gal/acre	1,070.85 gal	\$40.82	\$2,408.19
	Actagro Structure 7-21-0	Organic acids including Humic and Fulvic, Nitrogen, Phosphate, and Zinc	7 gal/acre	413 gal	\$56.00	\$3,304.00
					Total \$14,719.03	
Potato Spring Fertilizer 59 acre Oct 14, 2016 Fertilizer Application	Valley 21-0-0-24s	Nitrogen and Sulfur	380 lbs/acre	22,420 lbs	\$57.46	\$3,389.90
	Variable Rate Ground - spreading 1		1 acre/acre	59 acre	\$10.00	\$590.00
					Total \$3,979.90	
Potato Fall Fertilizer 59 acre Oct 14, 2016 Fertilizer Application	Valley 12-45-0-5-1Z	Sulfur, Nitrogen, Phosphate, and Zinc	302 lbs/acre	17,818 lbs	\$82.26	\$4,853.62
	Valley 0-0-60	Potash	150 lbs/acre	8,850 lbs	\$25.92	\$1,529.28
	K-Mag	Potash, Magnesium, and Sulfur	93 lbs/acre	5,487 lbs	\$25.44	\$1,501.24
	Elemental Sulphur 85%	Sulfur	117 lbs/acre	6,903 lbs	\$27.38	\$1,615.30
	Power Zinc 35 Granular	Sulfur and Zinc	14 lbs/acre	826 lbs	\$7.93	\$467.85
	Agfinity Manganese Sulfate 32%	Sulfur and Manganese	6.25 lbs/acre	368.75 lbs	\$4.61	\$272.14
Variable Rate Ground - spreading 1		1 acre/acre	59 acre	\$14.00	\$826.00	
					Total \$11,065.43	

SITUATION/ TIMING	INPUTS	ACTIVE	APPLY	UNITS	COST / ACRE	COST
Potato Prep Fumigation 59 acre Oct 14, 2016	Vapam HL Soil Fumigant	Metam-Sodium	40 gal/acre	2,360 gal	\$240.00	\$14,160.00
Soil Shank Injection	Deep Ripping		1 acre/acre	59 acre	\$40.00	\$2,360.00
					Total	\$16,520.00
Stubble Digest Sulfuric Acid 59 acre Oct 14, 2016	Sulfuric Acid	Sulfur	30 gal/acre	1,770 gal	\$27.00	\$1,593.00
Boomspray	Boomspray - contract		1 acre/acre	59 acre	\$12.00	\$708.00
					Total	\$2,301.00
Potatoes-Fungicide/Insecticide-Zing!, Abba Ultra, Masterlock 59 acre Oct 14, 2016	Zing!	Zoxamide and Chlorothalonil	1 qt/acre	14.75 gal	\$17.50	\$1,032.50
	ABBA Ultra	Abamectin	8 floz/acre	3.69 gal	\$6.56	\$387.19
	Masterlock	Modified vegetable oil, polyoxyethylene sorbitan fatty acid ester, vegetable oil, and soybean oil, ethoxylated	6 floz/acre	2.77 gal	\$1.17	\$69.14
Aerial Spraying	Spray/aerial		1 acre/acre	59 acre	\$10.00	\$590.00
					Total	\$2,078.83
Potato Harvest 59 acre Oct 14, 2016	Harvest		1 acre/acre	59 acre	\$50.00	\$2,950.00
					Total	\$2,950.00
Potatoes-Desiccant-Reglone, Parazone, Aduro 59 acre Oct 14, 2016	Water Rate		2,560 floz/acre	1,180 gal		
	Reglone Desiccant	Diquat as the diquat dibromide	2 pt/acre	14.75 gal	\$23.25	\$1,371.75
	Parazone 3SL	Paraquat Dichloride	1 pt/acre	7.38 gal	\$3.75	\$221.25
	Aduro	Monocarbamide dihydrogen sulfate, alkyl amine ethoxylate, 1,2,3-trihydroxypropane	2 pt/100gal	2.95 gal	\$1.10	\$64.90
Self Propelled Boomspray	Boomspray application		1 acre/acre	59 acre	\$8.00	\$472.00
					Total	\$2,129.90
Potato Seed Cutting 59 acre Oct 14, 2016	Seed - Treatment		1 acre/acre	59 acre	\$1.00	\$59.00
	Advise Four Flowable Insecticide	Imidacloprid	4 floz/100lb	0 gal	\$0.00	\$0.00
	Power-Line Potato Seed Treat Mancozeb 6% Plus Bark	Mancozeb	0.75 lbs/100lb	0 lbs	\$0.00	\$0.00
					Total	\$59.00
White Mold/Early Blight Application 59 acre Oct 14, 2016	Luna Tranquility	Fluopyram and Pyrimethanil	11 floz/acre	5.07 gal	\$34.37	\$2,028.12
Self Propelled Boomspray	Boomspray application		1 acre/acre	59 acre	\$8.00	\$472.00
					Total	\$2,500.13
White Mold/Early Blight 59 acre Oct 14, 2016	Endura Fungicide	Boscalid	6 oz/acre	22.13 lbs	\$33.60	\$1,982.40
	UPI Manzate Pro Stick	Mancozeb	1 lbs/acre	59 lbs	\$5.70	\$336.30
Boomspray	Boomspray application		1 acre/acre	59 acre	\$8.00	\$472.00
					Total	\$2,790.70
Potato Herbicide 59 acre Oct 14, 2016	Prowl H2O Herbicide	Pendimethalin	1.5 pt/acre	11.06 gal	\$9.00	\$531.00
	Boundary 6.5 EC Herbicide	Metribuzin and S-Metolachlor	2 pt/acre	14.75 gal	\$22.50	\$1,327.50
	Dimetric DF 75%	Metribuzin	0.33 lbs/acre	19.47 lbs	\$4.29	\$253.11
Self Propelled Boomspray	Boomspray application		1 acre/acre	59 acre	\$8.00	\$472.00
					Total	\$2,583.61

SITUATION/ TIMING	INPUTS	ACTIVE	APPLY	UNITS	COST / ACRE	COST
Potato Planting 59 acre Oct 14, 2016	Planting		1 acre/acre	59 acre	\$25.00	\$1,475.00
	Russet Burbank		28 lbs/acre	1,652 lbs	\$2.52	\$148.68
	Valley Agronomics 11-37-0	Phosphate and Nitrogen	13 gal/acre	767 gal	\$53.37	\$3,148.69
	Actagro Liquid Humus 0-0-4	Potash	2 qt/acre	29.5 gal	\$7.50	\$442.50
	Winfield Liquid Zinc 7%	Sulfur and Zinc	1 pt/acre	7.38 gal	\$0.75	\$44.25
	Moncut 70-DF	Flutolanil	0.75 lbs/acre	44.25 lbs	\$27.00	\$1,593.00
					Total	\$6,852.12
					Total	\$0.00
					Total	\$70,529.65

HARVEST ACTIVITIES

SITUATION/TIMING	HARVESTED WEIGHT	PRICE	INCOME
Harvest 2016 59 acre Nov 15, 2017	1,180 ton	\$120.00 /ton	\$141,600.00
Total	1,180 ton	\$120.00 /ton	\$141,600.00

Reservoir 2

FIELD SUMMARY

Costs	Income	Gross Profit	Gross Margin
\$1,195.42 /acre Total: \$101,634	\$2,879.32 /acre Total: \$244,800.00	\$1,683.90 /acre Total: \$143,166	58.48 %

INCOME SUMMARY

AREA	YIELD	PRICE	OTHER INCOME	TOTAL INCOME
85.02 acre	23.99 ton/acre	\$120.00 /ton	\$0.00	\$244,800.00

COST SUMMARY

SEED	FERTILIZER	CHEMICALS	CONTRACTORS	OPERATIONS	OTHER COSTS	TOTAL COST
\$2.52 /acre	\$554.10 /acre	\$429.80 /acre	\$0.00 /acre	\$209.00 /acre	\$0.00 /acre	\$1,195.42 /acre

ROTATION HISTORY

2016

Potato

85.02 acre | Russet Burbank

Active Ingredients: N 357.35 lbs/acre Phosphate 209.65 lbs/acre K2O 0.2 lbs/acre Potash 110.46 lbs/acre S 425.3 lbs/acre Mg 10.04 lbs/acre Mn 2 lbs/acre Zn 8.15 lbs/acre Organic acids including Humic and Fulvic 5.32 lbs/acre

ACTIVITIES

SITUATION/ TIMING	INPUTS	ACTIVE	APPLY	UNITS	COST / ACRE	COST
Potato Irrigation/ Fertigation 85.02 acre Oct 14, 2016 Fertigation	Irrigation		1 acre/acre	85.02 acre	\$15.00	\$1,275.30
	Valley Agronomics 32-0-0	Nitrogen	55 gal/acre	4,676.1 gal	\$137.66	\$11,703.71
	Thio-Sul (12-0-0-26S)	Sulfur and Nitrogen	18.15 gal/acre	1,543.11 gal	\$40.82	\$3,470.25
	Actagro Structure 7-21-0	Organic acids including Humic and Fulvic, Nitrogen, Phosphate, and Zinc	7 gal/acre	595.14 gal	\$56.00	\$4,761.12
					Total	\$21,210.37
Potato Spring Fertilizer 85.02 acre Oct 14, 2016 Fertilizer Application	Valley 21-0-0-24s	Nitrogen and Sulfur	380 lbs/acre	32,307.6 lbs	\$57.46	\$4,884.91
	Variable Rate Ground - spreading 1		1 acre/acre	85.02 acre	\$10.00	\$850.20
					Total	\$5,735.11

SITUATION/ TIMING	INPUTS	ACTIVE	APPLY	UNITS	COST / ACRE	COST
Potato Fall Fertilizer 85.02 acre Oct 14, 2016 Fertilizer Application	Valley 12-45-0-5-1Z	Sulfur, Nitrogen, Phosphate, and Zinc	302 lbs/acre	25,676.04 lbs	\$82.26	\$6,994.15
	Valley 0-0-60	Potash	150 lbs/acre	12,753 lbs	\$25.92	\$2,203.72
	K-Mag	Potash, Magnesium, and Sulfur	93 lbs/acre	7,906.86 lbs	\$25.44	\$2,163.32
	Elemental Sulphur 85%	Sulfur	117 lbs/acre	9,947.34 lbs	\$27.38	\$2,327.68
	Power Zinc 35 Granular	Sulfur and Zinc	14 lbs/acre	1,190.28 lbs	\$7.93	\$674.17
	Agfinity Manganese Sulfate 32%	Sulfur and Manganese	6.25 lbs/acre	531.38 lbs	\$4.61	\$392.15
Variable Rate Ground - spreading 1			1 acre/acre	85.02 acre	\$14.00	\$1,190.28
					Total	\$15,945.48
Potato Prep Fumigation 85.02 acre Oct 14, 2016 Soil Shank Injection	Vapam HL Soil Fumigant	Metam-Sodium	40 gal/acre	3,400.8 gal	\$240.00	\$20,404.80
	Deep Ripping		1 acre/acre	85.02 acre	\$40.00	\$3,400.80
					Total	\$23,805.60
Stubble Digest Sulfuric Acid 85.02 acre Oct 14, 2016 Boomspray	Sulfuric Acid	Sulfur	30 gal/acre	2,550.6 gal	\$27.00	\$2,295.54
	Boomspray - contract		1 acre/acre	85.02 acre	\$12.00	\$1,020.24
					Total	\$3,315.78
Potatoes-Fungicide/Insecticide-Zing!, Abba Ultra, Masterlock 85.02 acre Oct 14, 2016 Aerial Spraying	Zing!	Zoxamide and Chlorothalonil	1 qt/acre	21.26 gal	\$17.50	\$1,487.85
	ABBA Ultra	Abamectin	8 floz/acre	5.31 gal	\$6.56	\$557.94
	Masterlock	Modified vegetable oil, polyoxyethylene sorbitan fatty acid ester, vegetable oil, and soybean oil, ethoxylated	6 floz/acre	3.99 gal	\$1.17	\$99.63
	Spray/aerial		1 acre/acre	85.02 acre	\$10.00	\$850.20
					Total	\$2,995.63
Potato Harvest 85.02 acre Oct 14, 2016	Harvest		1 acre/acre	85.02 acre	\$50.00	\$4,251.00
						Total
Potatoes-Desiccant-Reglone, Parazone, Aduro 85.02 acre Oct 14, 2016 Self Propelled Boomspray	Water Rate		2,560 floz/acre	1,700.4 gal		
	Reglone Desiccant	Diquat as the diquat dibromide	2 pt/acre	21.26 gal	\$23.25	\$1,976.72
	Parazone 3SL	Paraquat Dichloride	1 pt/acre	10.63 gal	\$3.75	\$318.82
	Aduro	Monocarbamide dihydrogen sulfate, alkyl amine ethoxylate, 1,2,3-trihydroxypropane	2 pt/100gal	4.25 gal	\$1.10	\$93.52
	Boomspray application		1 acre/acre	85.02 acre	\$8.00	\$680.16
					Total	\$3,069.22
Potato Seed Cutting 85.02 acre Oct 14, 2016	Seed - Treatment		1 acre/acre	85.02 acre	\$1.00	\$85.02
	Advise Four Flowable Insecticide	Imidacloprid	4 floz/100lb	0 gal	\$0.00	\$0.00
	Power-Line Potato Seed Treat Mancozeb 6% Plus Bark	Mancozeb	0.75 lbs/100lb	0 lbs	\$0.00	\$0.00
					Total	\$85.02

SITUATION/ TIMING	INPUTS	ACTIVE	APPLY	UNITS	COST / ACRE	COST
White Mold/ Early Blight Application 85.02 acre	Luna Tranquility	Fluopyram and Pyrimethanil	11 floz/acre	7.31 gal	\$34.37	\$2,922.56
Oct 14, 2016 Self Propelled Boomspray	Boomspray application		1 acre/acre	85.02 acre	\$8.00	\$680.16
					Total	\$3,602.72
White Mold/ Early Blight 85.02 acre	Endura Fungicide	Boscalid	6 oz/acre	31.88 lbs	\$33.60	\$2,856.67
	UPI Manzate Pro Stick	Mancozeb	1 lbs/acre	85.02 lbs	\$5.70	\$484.61
Oct 14, 2016 Boomspray	Boomspray application		1 acre/acre	85.02 acre	\$8.00	\$680.16
					Total	\$4,021.45
Potato Herbicide 85.02 acre	Prowl H2O Herbicide	Pendimethalin	1.5 pt/acre	15.94 gal	\$9.00	\$765.18
	Boundary 6.5 EC Herbicide	Metribuzin and S- Metolachlor	2 pt/acre	21.26 gal	\$22.50	\$1,912.95
Oct 14, 2016 Self Propelled Boomspray	Dimetric DF 75% Boomspray application	Metribuzin	0.33 lbs/acre	28.06 lbs	\$4.29	\$364.74
			1 acre/acre	85.02 acre	\$8.00	\$680.16
					Total	\$3,723.03
Potato Planting 85.02 acre	Planting		1 acre/acre	85.02 acre	\$25.00	\$2,125.50
	Russet Burbank		28 lbs/acre	2,380.56 lbs	\$2.52	\$214.25
Oct 14, 2016	Valley Agronomics 11-37-0	Phosphate and Nitrogen	13 gal/acre	1,105.26 gal	\$53.37	\$4,537.31
	Actagro Liquid Humus 0-0-4	Potash	2 qt/acre	42.51 gal	\$7.50	\$637.65
	Winfield Liquid Zinc 7%	Sulfur and Zinc	1 pt/acre	10.63 gal	\$0.75	\$63.76
	Moncut 70-DF	Flutolanil	0.75 lbs/acre	63.76 lbs	\$27.00	\$2,295.54
					Total	\$9,874.02
					Total	\$0.00
					Total	\$101,634.42

HARVEST ACTIVITIES

SITUATION/TIMING	HARVESTED WEIGHT	PRICE	INCOME
Harvest 2016 85.02 acre	2,040 ton	\$120.00 /ton	\$244,800.00
Nov 15, 2017			
Total	2,040 ton	\$120.00 /ton	\$244,800.00

Reservoir 3

FIELD SUMMARY

Costs	Income	Gross Profit	Gross Margin
\$1,195.42 /acre Total: \$163,175	\$2,510.77 /acre Total: \$342,720.00	\$1,315.35 /acre Total: \$179,545	52.39 %

INCOME SUMMARY

AREA	YIELD	PRICE	OTHER INCOME	TOTAL INCOME
136.5 acre	20.92 ton/acre	\$120.00 /ton	\$0.00	\$342,720.00

COST SUMMARY

SEED	FERTILIZER	CHEMICALS	CONTRACTORS	OPERATIONS	OTHER COSTS	TOTAL COST
\$2.52 /acre	\$554.10 /acre	\$429.80 /acre	\$0.00 /acre	\$209.00 /acre	\$0.00 /acre	\$1,195.42 /acre

ROTATION HISTORY

2016

Potato

136.5 acre | Russet Burbank

Active Ingredients: N 357.35 lbs/acre Phosphate 209.65 lbs/acre K2O 0.2 lbs/acre Potash 110.46 lbs/acre S 425.3 lbs/acre Mg 10.04 lbs/acre Mn 2 lbs/acre Zn 8.15 lbs/acre Organic acids including Humic and Fulvic 5.32 lbs/acre

ACTIVITIES

SITUATION/ TIMING	INPUTS	ACTIVE	APPLY	UNITS	COST / ACRE	COST
Potato Irrigation/ Fertigation 136.5 acre Oct 14, 2016 Fertigation	Irrigation		1 acre/acre	136.5 acre	\$15.00	\$2,047.50
	Valley Agronomics 32-0-0	Nitrogen	55 gal/acre	7,507.5 gal	\$137.66	\$18,790.36
	Thio-Sul (12-0-0-26S)	Sulfur and Nitrogen	18.15 gal/acre	2,477.48 gal	\$40.82	\$5,571.49
	Actagro Structure 7-21-0	Organic acids including Humic and Fulvic, Nitrogen, Phosphate, and Zinc	7 gal/acre	955.5 gal	\$56.00	\$7,644.00
					Total	\$34,053.35
Potato Spring Fertilizer 136.5 acre Oct 14, 2016 Fertilizer Application	Valley 21-0-0-24s	Nitrogen and Sulfur	380 lbs/acre	51,870 lbs	\$57.46	\$7,842.74
	Variable Rate Ground - spreading 1		1 acre/acre	136.5 acre	\$10.00	\$1,365.00
					Total	\$9,207.74

SITUATION/ TIMING	INPUTS	ACTIVE	APPLY	UNITS	COST / ACRE	COST
Potato Fall Fertilizer 136.5 acre Oct 14, 2016 Fertilizer Application	Valley 12-45-0-5-1Z	Sulfur, Nitrogen, Phosphate, and Zinc	302 lbs/acre	41,223 lbs	\$82.26	\$11,229.15
	Valley 0-0-60	Potash	150 lbs/acre	20,475 lbs	\$25.92	\$3,538.08
	K-Mag	Potash, Magnesium, and Sulfur	93 lbs/acre	12,694.5 lbs	\$25.44	\$3,473.22
	Elemental Sulphur 85%	Sulfur	117 lbs/acre	15,970.5 lbs	\$27.38	\$3,737.10
	Power Zinc 35 Granular	Sulfur and Zinc	14 lbs/acre	1,911 lbs	\$7.93	\$1,082.39
	Agfinity Manganese Sulfate 32%	Sulfur and Manganese	6.25 lbs/acre	853.13 lbs	\$4.61	\$629.61
Variable Rate Ground - spreading 1			1 acre/acre	136.5 acre	\$14.00	\$1,911.00
					Total	\$25,600.53
Potato Prep Fumigation 136.5 acre Oct 14, 2016 Soil Shank Injection	Vapam HL Soil Fumigant	Metam-Sodium	40 gal/acre	5,460 gal	\$240.00	\$32,760.00
	Deep Ripping		1 acre/acre	136.5 acre	\$40.00	\$5,460.00
					Total	\$38,220.00
Stubble Digest Sulfuric Acid 136.5 acre Oct 14, 2016 Boomspray	Sulfuric Acid	Sulfur	30 gal/acre	4,095 gal	\$27.00	\$3,685.50
	Boomspray - contract		1 acre/acre	136.5 acre	\$12.00	\$1,638.00
					Total	\$5,323.50
Potatoes-Fungicide/Insecticide-Zing!, Abba Ultra, Masterlock 136.5 acre Oct 14, 2016 Aerial Spraying	Zing!	Zoxamide and Chlorothalonil	1 qt/acre	34.13 gal	\$17.50	\$2,388.75
	ABBA Ultra	Abamectin	8 floz/acre	8.53 gal	\$6.56	\$895.78
	Masterlock	Modified vegetable oil, polyoxyethylene sorbitan fatty acid ester, vegetable oil, and soybean oil, ethoxylated	6 floz/acre	6.4 gal	\$1.17	\$159.96
	Spray/aerial		1 acre/acre	136.5 acre	\$10.00	\$1,365.00
					Total	\$4,809.49
Potato Harvest 136.5 acre Oct 14, 2016	Harvest		1 acre/acre	136.5 acre	\$50.00	\$6,825.00
						Total
Potatoes-Desiccant-Reglone, Parazone, Aduro 136.5 acre Oct 14, 2016 Self Propelled Boomspray	Water Rate		2,560 floz/acre	2,730 gal		
	Reglone Desiccant	Diquat as the diquat dibromide	2 pt/acre	34.13 gal	\$23.25	\$3,173.63
	Parazone 3SL	Paraquat Dichloride	1 pt/acre	17.06 gal	\$3.75	\$511.87
	Aduro	Monocarbamide dihydrogen sulfate, alkyl amine ethoxylate, 1,2,3-trihydroxypropane	2 pt/100gal	6.83 gal	\$1.10	\$150.15
	Boomspray application		1 acre/acre	136.5 acre	\$8.00	\$1,092.00
					Total	\$4,927.65
Potato Seed Cutting 136.5 acre Oct 14, 2016	Seed - Treatment		1 acre/acre	136.5 acre	\$1.00	\$136.50
	Advise Four Flowable Insecticide	Imidacloprid	4 floz/100lb	0 gal	\$0.00	\$0.00
	Power-Line Potato Seed Treat Mancozeb 6% Plus Bark	Mancozeb	0.75 lbs/100lb	0 lbs	\$0.00	\$0.00
					Total	\$136.50
White Mold/Early Blight Application 136.5 acre Oct 14, 2016 Self Propelled Boomspray	Luna Tranquility	Fluopyram and Pyrimethanil	11 floz/acre	11.73 gal	\$34.37	\$4,692.19
	Boomspray application		1 acre/acre	136.5 acre	\$8.00	\$1,092.00
					Total	\$5,784.19

SITUATION/ TIMING	INPUTS	ACTIVE	APPLY	UNITS	COST / ACRE	COST
White Mold/ Early Blight 136.5 acre	Endura Fungicide	Boscalid	6 oz/acre	51.19 lbs	\$33.60	\$4,586.40
	UPI Manzate Pro Stick	Mancozeb	1 lbs/acre	136.5 lbs	\$5.70	\$778.05
Oct 14, 2016 Boomspray	Boomspray application		1 acre/acre	136.5 acre	\$8.00	\$1,092.00
					Total	\$6,456.45
Potato Herbicide 136.5 acre	Prowl H2O Herbicide	Pendimethalin	1.5 pt/acre	25.59 gal	\$9.00	\$1,228.50
	Boundary 6.5 EC Herbicide	Metribuzin and S- Metolachlor	2 pt/acre	34.13 gal	\$22.50	\$3,071.25
Oct 14, 2016 Self Propelled Boomspray	Dimetric DF 75%	Metribuzin	0.33 lbs/acre	45.05 lbs	\$4.29	\$585.59
		Boomspray application	1 acre/acre	136.5 acre	\$8.00	\$1,092.00
					Total	\$5,977.34
Potato Planting 136.5 acre	Planting		1 acre/acre	136.5 acre	\$25.00	\$3,412.50
	Russet Burbank		28 lbs/acre	3,822 lbs	\$2.52	\$343.98
Oct 14, 2016	Valley Agronomics 11-37-0	Phosphate and Nitrogen	13 gal/acre	1,774.5 gal	\$53.37	\$7,284.68
		Actagro Liquid Humus 0-0-4	2 qt/acre	68.25 gal	\$7.50	\$1,023.75
		Winfield Liquid Zinc 7%	1 pt/acre	17.06 gal	\$0.75	\$102.38
		Moncut 70-DF	0.75 lbs/acre	102.38 lbs	\$27.00	\$3,685.50
					Total	\$15,852.78
					Total	\$0.00
					Total	\$163,174.53

HARVEST ACTIVITIES

SITUATION/TIMING	HARVESTED WEIGHT	PRICE	INCOME
Harvest 2016 136.5 acre	2,856 ton	\$120.00 /ton	\$342,720.00
Nov 15, 2017			
Total	2,856 ton	\$120.00 /ton	\$342,720.00

Reservoir 4

FIELD SUMMARY

Costs	Income	Gross Profit	Gross Margin
\$918.40 /acre Total: \$36,735.80	\$540.00 /acre Total: \$21,600.00	\$-378.40 /acre Total: \$-15,135.80	-70.07 %

INCOME SUMMARY

AREA	YIELD	PRICE	OTHER INCOME	TOTAL INCOME
40 acre	120 bu/acre	\$4.50 /bu	\$0.00	\$21,600.00

COST SUMMARY

SEED	FERTILIZER	CHEMICALS	CONTRACTORS	OPERATIONS	OTHER COSTS	TOTAL COST
\$21.96 /acre	\$301.56 /acre	\$84.38 /acre	\$0.00 /acre	\$510.50 /acre	\$0.00 /acre	\$918.40 /acre

ROTATION HISTORY

2016

Wheat - winter

40 acre | Brundage 96

Active Ingredients: N 443.69 lbs/acre Phosphate 201.24 lbs/acre K2O 201.6 lbs/acre

ACTIVITIES

SITUATION/ TIMING	INPUTS	ACTIVE	APPLY	UNITS	COST / ACRE	COST
Spring Fertilizer 40 acre Mar 24, 2016 Spreader	Andersons 46-0-0	Nitrogen	218 lbs/acre	8,720 lbs	\$39.24	\$1,569.60
	Muriate of Potash 0-0-60	Potash	84 lbs/acre	3,360 lbs	\$16.80	\$672.00
	Agrium 11-52-0 MAP	Nitrogen and Phosphate	97 lbs/acre	3,880 lbs	\$19.40	\$776.00
	Spreading fertilizer		1 acre/acre	40 acre	\$10.00	\$400.00
					Total	\$3,417.60
Spring Fertilizer 40 acre Mar 31, 2016 Spreader	Andersons 46-0-0	Nitrogen	218 lbs/acre	8,720 lbs	\$39.24	\$1,569.60
	Muriate of Potash 0-0-60	Potash	84 lbs/acre	3,360 lbs	\$16.80	\$672.00
	Agrium 11-52-0 MAP	Nitrogen and Phosphate	97 lbs/acre	3,880 lbs	\$19.40	\$776.00
	Spreading fertilizer		1 acre/acre	40 acre	\$10.00	\$400.00
					Total	\$3,417.60
Herbicide Application 40 acre Apr 01, 2016 Self Propelled Boomspray	Water Rate		1,920 floz/acre	600 gal		
	Huskie Herbicide	Bromoxynil Octanoic Acid Ester, Pyrasulfotole, and Bromoxynil Heptanoate	15 floz/acre	4.69 gal	\$9.38	\$375.00
	Class Act NG	Ammonium sulfate, corn syrup, alkyl polyglycoside	16 floz/acre	5 gal	\$2.50	\$100.00
	DuPont Aproach Fungicide Spray/herbicide	Picoxystrobin (stobilurin)	4 floz/acre	1.25 gal	\$5.00	\$200.00
			1 acre/acre	40 acre	\$10.00	\$400.00
					Total	\$1,075.00



SITUATION/ TIMING	INPUTS	ACTIVE	APPLY	UNITS	COST / ACRE	COST
Planting 40 acre May 19, 2016	Brundage 96		120 lbs/acre	4,800 lbs	\$12.00	\$480.00
	Planting		1 acre/acre	40 acre	\$6.00	\$240.00
					Total	\$720.00
Ethephon 40 acre May 31, 2016	Water Rate		640 floz/acre	200 gal		
	MANA Ethephon 2SL	Ethephon	1.5 pt/acre	7.5 gal	\$15.00	\$600.00
	Spray/aerial		1 acre/acre	40 acre	\$8.00	\$320.00
Aerial Spraying	Topaz	Propiconazole	4 floz/acre	1.25 gal	\$1.87	\$75.00
					Total	\$995.00
Spring Fertilizer 40 acre Jul 21, 2016	Power-Line Urea 46-0-0 Granular	Nitrogen	218 lbs/acre	8,720 lbs	\$39.24	\$1,569.60
Fertilizer Application	Muriate of Potash 0-0-60	Potash	84 lbs/acre	3,360 lbs	\$16.80	\$672.00
	Simplot Monoammonium Phosphate 11-52-0	Nitrogen and Phosphate	96 lbs/acre	3,840 lbs	\$19.20	\$768.00
	Fertilizer Application		40 acre/acre	1,600 acre	\$400.00	\$16,000.00
					Total	\$19,009.60
Harvest 40 acre Aug 05, 2016	Mechanical harvesting		1 acre/acre	40 acre	\$10.00	\$400.00
					Total	\$400.00
Irrigation 40 acre Oct 14, 2016	Irrigation		1 acre/acre	40 acre	\$10.00	\$400.00
					Total	\$400.00
Harvest 40 acre Oct 14, 2016	Harvest		1 acre/acre	40 acre	\$4.50	\$180.00
					Total	\$180.00
Planting 40 acre Oct 14, 2016	Planting		1 acre/acre	40 acre	\$4.00	\$160.00
	Brundage 96		120 lbs/acre	4,800 lbs	\$9.96	\$398.40
					Total	\$558.40
Ethephon 40 acre Oct 14, 2016	Water Rate		640 floz/acre	200 gal		
	MANA Ethephon 2SL	Ethephon	1.5 pt/acre	7.5 gal	\$15.00	\$600.00
	Spray/aerial		1 acre/acre	40 acre	\$8.00	\$320.00
Aerial Spraying	Topaz	Propiconazole	4 floz/acre	1.25 gal	\$1.87	\$75.00
					Total	\$995.00
Herbicide Application 40 acre Oct 14, 2016	Water Rate		1,920 floz/acre	600 gal		
Self Propelled Boomspray	Huskie Herbicide	Bromoxynil Octanoic Acid Ester, Pyrasulfotole, and Bromoxynil Heptanoate	15 floz/acre	4.69 gal	\$9.38	\$375.00
	Class Act NG	Ammonium sulfate, corn syrup, alkyl polyglycoside	16 floz/acre	5 gal	\$2.50	\$100.00
	DuPont Aproach Fungicide	Picoxystrobin (stobilurin)	4 floz/acre	1.25 gal	\$5.00	\$200.00
	Spray/herbicide		1 acre/acre	40 acre	\$10.00	\$400.00
					Total	\$1,075.00
Spring Fertilizer 40 acre Oct 14, 2016	Andersons 46-0-0	Nitrogen	218 lbs/acre	8,720 lbs	\$39.24	\$1,569.60
Spread	Muriate of Potash 0-0-60	Potash	84 lbs/acre	3,360 lbs	\$16.80	\$672.00
	Agrium 11-52-0 MAP	Nitrogen and Phosphate	97 lbs/acre	3,880 lbs	\$19.40	\$776.00
	Spreading fertilizer		1 acre/acre	40 acre	\$10.00	\$400.00
					Total	\$3,417.60
					Total	\$0.00

SITUATION/ TIMING	INPUTS	ACTIVE	APPLY	UNITS	COST / ACRE	COST
Herbicide Application 40 acre Jan 17, 2018 Self Propelled Boomspray	Water Rate		1,920 floz/acre	600 gal		
	Huskie Herbicide	Bromoxynil Octanoic Acid Ester, Pyrasulfotole, and Bromoxynil Heptanoate	15 floz/acre	4.69 gal	\$9.38	\$375.00
	Class Act NG	Ammonium sulfate, corn syrup, alkyl polyglycoside	16 floz/acre	5 gal	\$2.50	\$100.00
	DuPont Aproach Fungicide	Picoxystrobin (stobilurin)	4 floz/acre	1.25 gal	\$5.00	\$200.00
	Spray/herbicide		1 acre/acre	40 acre	\$10.00	\$400.00
					Total	\$1,075.00
						Total \$36,735.80

HARVEST ACTIVITIES

SITUATION/TIMING		HARVESTED WEIGHT	PRICE	INCOME
Harvest 2016 40 acre Nov 15, 2017		4,800 bu	\$4.50 /bu	\$21,600.00
	Total	4,800 bu	\$4.50 /bu	\$21,600.00

Grandview Aerial Overview

Potato  Wheat - winter 

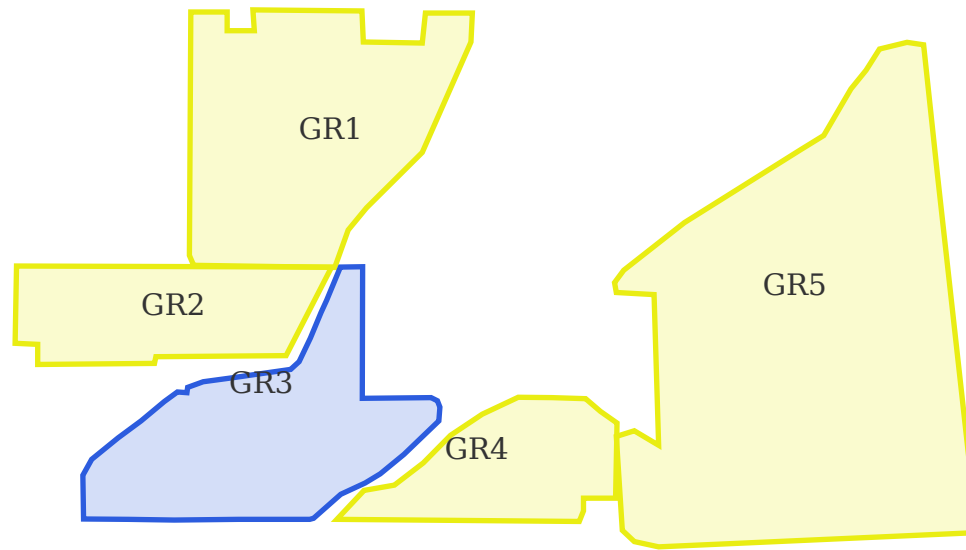

GROSS PROFIT BY ROTATION HISTORY - Grandview

FIELD	2016
Grandview 1 (Map : GR1)	Wheat - winter Brundage 96 \$298.55 /acre
Grandview 2 (Map : GR2)	Wheat - winter Brundage 96 \$281.00 /acre
Grandview 3 (Map : GR3)	Potato Russet Burbank \$1,780.64 /acre
Grandview 4 (Map : GR4)	Wheat - winter Brundage 96 \$198.75 /acre
Grandview 5 (Map : GR5)	Wheat - winter Brundage 96 \$321.04 /acre

Grandview 1

FIELD SUMMARY

Costs	Income	Gross Profit	Gross Margin
\$165.65 /acre Total: \$16,392.72	\$464.20 /acre Total: \$45,937.50	\$298.55 /acre Total: \$29,544.78	64.32 %

INCOME SUMMARY

AREA	YIELD	PRICE	OTHER INCOME	TOTAL INCOME
98.96 acre	123.79 bu/acre	\$3.75 /bu	\$0.00	\$45,937.50

COST SUMMARY

SEED	FERTILIZER	CHEMICALS	CONTRACTORS	OPERATIONS	OTHER COSTS	TOTAL COST
\$9.96 /acre	\$75.44 /acre	\$33.75 /acre	\$0.00 /acre	\$46.50 /acre	\$0.00 /acre	\$165.65 /acre

ROTATION HISTORY

2016

Wheat - winter

98.96 acre | Brundage 96

Active Ingredients: N 110.95 lbs/acre Phosphate 50.44 lbs/acre K2O 50.4 lbs/acre

ACTIVITIES

SITUATION/ TIMING	INPUTS	ACTIVE	APPLY	UNITS	COST / ACRE	COST
Irrigation 98.96 acre Oct 14, 2016	Irrigation		1 acre/acre	98.96 acre	\$10.00	\$989.60
					Total	\$989.60
Harvest 98.96 acre Oct 14, 2016	Harvest		1 acre/acre	98.96 acre	\$4.50	\$445.32
					Total	\$445.32
Planting 98.96 acre Oct 14, 2016	Planting		1 acre/acre	98.96 acre	\$4.00	\$395.84
	Brundage 96		120 lbs/acre	11,875.2 lbs	\$9.96	\$985.64
					Total	\$1,381.48
Ethephon 98.96 acre Oct 14, 2016	Water Rate		640 floz/acre	494.8 gal		
	MANA Ethephon 2SL	Ethephon	1.5 pt/acre	18.55 gal	\$15.00	\$1,484.40
	Spray/aerial		1 acre/acre	98.96 acre	\$8.00	\$791.68
Aerial Spraying	Topaz	Propiconazole	4 floz/acre	3.09 gal	\$1.87	\$185.55
					Total	\$2,461.63

SITUATION/ TIMING	INPUTS	ACTIVE	APPLY	UNITS	COST / ACRE	COST
Herbicide Application 98.96 acre Oct 14, 2016 Self Propelled Boomspray	Water Rate		1,920 floz/acre	1,484.4 gal		
	Huskie Herbicide	Bromoxynil Octanoic Acid Ester, Pyrasulfotole, and Bromoxynil Heptanoate	15 floz/acre	11.6 gal	\$9.38	\$927.75
	Class Act NG	Ammonium sulfate, corn syrup, alkyl polyglycoside	16 floz/acre	12.37 gal	\$2.50	\$247.40
	DuPont Aproach Fungicide	Picoxystrobin (stobilurin)	4 floz/acre	3.09 gal	\$5.00	\$494.80
	Spray/herbicide		1 acre/acre	98.96 acre	\$10.00	\$989.60
					Total	\$2,659.55
Spring Fertilizer 98.96 acre Oct 14, 2016 Spreader	Andersons 46-0-0	Nitrogen	218 lbs/acre	21,573.28 lbs	\$39.24	\$3,883.19
	Muriate of Potash 0-0-60	Potash	84 lbs/acre	8,312.64 lbs	\$16.80	\$1,662.53
	Agrium 11-52-0 MAP	Nitrogen and Phosphate	97 lbs/acre	9,599.12 lbs	\$19.40	\$1,919.82
	Spreading fertilizer		1 acre/acre	98.96 acre	\$10.00	\$989.60
					Total	\$8,455.14
					Total	\$0.00
					Total	\$16,392.72

HARVEST ACTIVITIES

SITUATION/TIMING	HARVESTED WEIGHT	PRICE	INCOME
Harvest 2016 98.96 acre Nov 15, 2017	12,250 bu	\$3.75 /bu	\$45,937.50
Total	12,250 bu	\$3.75 /bu	\$45,937.50

Grandview 2

FIELD SUMMARY

Costs	Income	Gross Profit	Gross Margin
\$165.65 /acre Total: \$8,010.83	\$446.65 /acre Total: \$21,600.00	\$281.00 /acre Total: \$13,589.17	62.91 %

INCOME SUMMARY

AREA	YIELD	PRICE	OTHER INCOME	TOTAL INCOME
48.36 acre	119.11 bu/acre	\$3.75 /bu	\$0.00	\$21,600.00

COST SUMMARY

SEED	FERTILIZER	CHEMICALS	CONTRACTORS	OPERATIONS	OTHER COSTS	TOTAL COST
\$9.96 /acre	\$75.44 /acre	\$33.75 /acre	\$0.00 /acre	\$46.50 /acre	\$0.00 /acre	\$165.65 /acre

ROTATION HISTORY

2016

Wheat - winter

48.36 acre | Brundage 96

Active Ingredients: N 110.95 lbs/acre Phosphate 50.44 lbs/acre K2O 50.4 lbs/acre

ACTIVITIES

SITUATION/ TIMING	INPUTS	ACTIVE	APPLY	UNITS	COST / ACRE	COST
Irrigation 48.36 acre Oct 14, 2016	Irrigation		1 acre/acre	48.36 acre	\$10.00	\$483.60
					Total	\$483.60
Harvest 48.36 acre Oct 14, 2016	Harvest		1 acre/acre	48.36 acre	\$4.50	\$217.62
					Total	\$217.62
Planting 48.36 acre Oct 14, 2016	Planting		1 acre/acre	48.36 acre	\$4.00	\$193.44
	Brundage 96		120 lbs/acre	5,803.2 lbs	\$9.96	\$481.67
					Total	\$675.11
Ethephon 48.36 acre Oct 14, 2016 Aerial Spraying	Water Rate		640 floz/acre	241.8 gal		
	MANA Ethephon 2SL	Ethephon	1.5 pt/acre	9.07 gal	\$15.00	\$725.40
	Spray/aerial		1 acre/acre	48.36 acre	\$8.00	\$386.88
	Topaz	Propiconazole	4 floz/acre	1.51 gal	\$1.87	\$90.68
					Total	\$1,202.96
Herbicide Application 48.36 acre Oct 14, 2016 Self Propelled Boomspray	Water Rate		1,920 floz/acre	725.4 gal		
	Huskie Herbicide	Bromoxynil Octanoic Acid Ester, Pyrasulfotole, and Bromoxynil Heptanoate	15 floz/acre	5.67 gal	\$9.38	\$453.38
	Class Act NG	Ammonium sulfate, corn syrup, alkyl polyglycoside	16 floz/acre	6.05 gal	\$2.50	\$120.90
	DuPont Aproach Fungicide	Picoxystrobin (stobilurin)	4 floz/acre	1.51 gal	\$5.00	\$241.80
	Spray/herbicide		1 acre/acre	48.36 acre	\$10.00	\$483.60
					Total	\$1,299.68

SITUATION/ TIMING	INPUTS	ACTIVE	APPLY	UNITS	COST / ACRE	COST
Spring Fertilizer 48.36 acre Oct 14, 2016 Spreader	Andersons 46-0-0	Nitrogen	218 lbs/acre	10,542.48 lbs	\$39.24	\$1,897.65
	Muriate of Potash 0-0-60	Potash	84 lbs/acre	4,062.24 lbs	\$16.80	\$812.45
	Agrium 11-52-0 MAP	Nitrogen and Phosphate	97 lbs/acre	4,690.92 lbs	\$19.40	\$938.18
	Spreading fertilizer		1 acre/acre	48.36 acre	\$10.00	\$483.60
					Total \$4,131.88	
					Total \$0.00	
					Total \$8,010.83	

HARVEST ACTIVITIES

SITUATION/TIMING	HARVESTED WEIGHT	PRICE	INCOME
Harvest 2016 48.36 acre Nov 15, 2017	5,760 bu	\$3.75 /bu	\$21,600.00
Total	5,760 bu	\$3.75 /bu	\$21,600.00

Grandview 3

FIELD SUMMARY

Costs	Income	Gross Profit	Gross Margin
\$1,196.17 /acre Total: \$92,822.62	\$2,976.80 /acre Total: \$231,000.00	\$1,780.64 /acre Total: \$138,177	59.82 %

INCOME SUMMARY

AREA	YIELD	PRICE	OTHER INCOME	TOTAL INCOME
77.6 acre	24.81 ton/acre	\$120.00 /ton	\$0.00	\$231,000.00

COST SUMMARY

SEED	FERTILIZER	CHEMICALS	CONTRACTORS	OPERATIONS	OTHER COSTS	TOTAL COST
\$2.52 /acre	\$554.10 /acre	\$429.80 /acre	\$0.00 /acre	\$209.75 /acre	\$0.00 /acre	\$1,196.17 /acre

ROTATION HISTORY

2016

Potato

77.6 acre | Russet Burbank

Active Ingredients: N 357.35 lbs/acre Phosphate 209.65 lbs/acre K2O 0.2 lbs/acre Potash 110.46 lbs/acre S 425.3 lbs/acre Mg 10.04 lbs/acre Mn 2 lbs/acre Zn 8.15 lbs/acre Organic acids including Humic and Fulvic 5.32 lbs/acre

ACTIVITIES

SITUATION/ TIMING	INPUTS	ACTIVE	APPLY	UNITS	COST / ACRE	COST
Potatoes- White Mold Early Blight- Luna Tranquility 77.6 acre Aug 30, 2016 Self Propelled Boomspray	Water Rate		2,560 floz/acre	1,552 gal		
	Luna Tranquility	Fluopyram and Pyrimethanil	11 floz/acre	6.67 gal	\$0.00	\$0.00
	Boomspray application		1 acre/acre	77.6 acre	\$0.00	\$0.00
					Total	\$0.00
Aerial Imagery 77.6 acre Oct 14, 2016	Field Scouting		1 acre/acre	77.6 acre	\$0.75	\$58.20
					Total	\$58.20
Potato Irrigation/ Fertigation 77.6 acre Oct 14, 2016 Fertigation	Irrigation		1 acre/acre	77.6 acre	\$15.00	\$1,164.00
	Valley Agronomics 32-0-0	Nitrogen	55 gal/acre	4,268 gal	\$137.66	\$10,682.28
	Thio-Sul (12-0-0-26S)	Sulfur and Nitrogen	18.15 gal/acre	1,408.44 gal	\$40.82	\$3,167.38
	Actagro Structure 7-21-0	Organic acids including Humic and Fulvic, Nitrogen, Phosphate, and Zinc	7 gal/acre	543.2 gal	\$56.00	\$4,345.60
					Total	\$19,359.27

SITUATION/ TIMING	INPUTS	ACTIVE	APPLY	UNITS	COST / ACRE	COST
Potato Spring Fertilizer 77.6 acre Oct 14, 2016 Fertilizer Application	Valley 21-0-0-24s	Nitrogen and Sulfur	380 lbs/acre	29,488 lbs	\$57.46	\$4,458.59
	Variable Rate Ground - spreading 1		1 acre/acre	77.6 acre	\$10.00	\$776.00
					Total	\$5,234.59
Potato Fall Fertilizer 77.6 acre Oct 14, 2016 Fertilizer Application	Valley 12-45-0-5-1Z	Sulfur, Nitrogen, Phosphate, and Zinc	302 lbs/acre	23,435.2 lbs	\$82.26	\$6,383.75
	Valley 0-0-60	Potash	150 lbs/acre	11,640 lbs	\$25.92	\$2,011.39
	K-Mag	Potash, Magnesium, and Sulfur	93 lbs/acre	7,216.8 lbs	\$25.44	\$1,974.52
	Elemental Sulphur 85%	Sulfur	117 lbs/acre	9,079.2 lbs	\$27.38	\$2,124.53
	Power Zinc 35 Granular	Sulfur and Zinc	14 lbs/acre	1,086.4 lbs	\$7.93	\$615.34
Agfinity Manganese Sulfate 32%	Sulfur and Manganese	6.25 lbs/acre	485 lbs	\$4.61	\$357.93	
Variable Rate Ground - spreading 1		1 acre/acre	77.6 acre	\$14.00	\$1,086.40	
					Total	\$14,553.86
Potato Prep Fumigation 77.6 acre Oct 14, 2016 Soil Shank Injection	Vapam HL Soil Fumigant	Metam-Sodium	40 gal/acre	3,104 gal	\$240.00	\$18,624.00
	Deep Ripping		1 acre/acre	77.6 acre	\$40.00	\$3,104.00
					Total	\$21,728.00
Stubble Digest Sulfuric Acid 77.6 acre Oct 14, 2016 Boomspray	Sulfuric Acid	Sulfur	30 gal/acre	2,328 gal	\$27.00	\$2,095.20
	Boomspray - contract		1 acre/acre	77.6 acre	\$12.00	\$931.20
					Total	\$3,026.40
Potatoes-Fungicide/Insecticide-Zing!, Abba Ultra, Masterlock 77.6 acre Oct 14, 2016 Aerial Spraying	Zing!	Zoxamide and Chlorothalonil	1 qt/acre	19.4 gal	\$17.50	\$1,358.00
	ABBA Ultra	Abamectin	8 floz/acre	4.85 gal	\$6.56	\$509.25
	Masterlock	Modified vegetable oil, polyoxyethylene sorbitan fatty acid ester, vegetable oil, and soybean oil, ethoxylated	6 floz/acre	3.64 gal	\$1.17	\$90.94
	Spray/aerial		1 acre/acre	77.6 acre	\$10.00	\$776.00
					Total	\$2,734.19
Potato Harvest 77.6 acre Oct 14, 2016	Harvest		1 acre/acre	77.6 acre	\$50.00	\$3,880.00
						Total
Potatoes-Desiccant-Reglone, Parazone, Aduro 77.6 acre Oct 14, 2016 Self Propelled Boomspray	Water Rate		2,560 floz/acre	1,552 gal		
	Reglone Desiccant	Diquat as the diquat dibromide	2 pt/acre	19.4 gal	\$23.25	\$1,804.20
	Parazone 3SL	Paraquat Dichloride	1 pt/acre	9.7 gal	\$3.75	\$291.00
	Aduro	Monocarbamide dihydrogen sulfate, alkyl amine ethoxylate, 1,2,3-trihydroxypropane	2 pt/100gal	3.88 gal	\$1.10	\$85.36
	Boomspray application		1 acre/acre	77.6 acre	\$8.00	\$620.80
					Total	\$2,801.36
Potato Seed Cutting 77.6 acre Oct 14, 2016	Seed - Treatment		1 acre/acre	77.6 acre	\$1.00	\$77.60
	Advise Four Flowable Insecticide	Imidacloprid	4 floz/100lb	0 gal	\$0.00	\$0.00
	Power-Line Potato Seed Treat Mancozeb 6% Plus Bark	Mancozeb	0.75 lbs/100lb	0 lbs	\$0.00	\$0.00
					Total	\$77.60

SITUATION/ TIMING	INPUTS	ACTIVE	APPLY	UNITS	COST / ACRE	COST
White Mold/ Early Blight Application 77.6 acre	Luna Tranquility	Fluopyram and Pyrimethanil	11 floz/acre	6.67 gal	\$34.38	\$2,667.50
Oct 14, 2016 Self Propelled Boomspray	Boomspray application		1 acre/acre	77.6 acre	\$8.00	\$620.80
					Total	\$3,288.30
White Mold/ Early Blight 77.6 acre	Endura Fungicide	Boscalid	6 oz/acre	29.1 lbs	\$33.60	\$2,607.36
	UPI Manzate Pro Stick	Mancozeb	1 lbs/acre	77.6 lbs	\$5.70	\$442.32
Oct 14, 2016 Boomspray	Boomspray application		1 acre/acre	77.6 acre	\$8.00	\$620.80
					Total	\$3,670.48
Potato Herbicide 77.6 acre	Prowl H2O Herbicide	Pendimethalin	1.5 pt/acre	14.55 gal	\$9.00	\$698.40
	Boundary 6.5 EC Herbicide	Metribuzin and S- Metolachlor	2 pt/acre	19.4 gal	\$22.50	\$1,746.00
Oct 14, 2016 Self Propelled Boomspray	Dimetric DF 75% Boomspray application	Metribuzin	0.33 lbs/acre	25.61 lbs	\$4.29	\$332.90
					Total	\$3,398.10
Potato Planting 77.6 acre	Planting		1 acre/acre	77.6 acre	\$25.00	\$1,940.00
	Russet Burbank		28 lbs/acre	2,172.8 lbs	\$2.52	\$195.55
Oct 14, 2016	Valley Agronomics 11-37-0	Phosphate and Nitrogen	13 gal/acre	1,008.8 gal	\$53.37	\$4,141.33
	Actagro Liquid Humus 0-0-4	Potash	2 qt/acre	38.8 gal	\$7.50	\$582.00
	Winfield Liquid Zinc 7%	Sulfur and Zinc	1 pt/acre	9.7 gal	\$0.75	\$58.20
	Moncut 70-DF	Flutolanil	0.75 lbs/acre	58.2 lbs	\$27.00	\$2,095.20
					Total	\$9,012.28
					Total	\$0.00
					Total	\$92,822.62

HARVEST ACTIVITIES

SITUATION/TIMING	HARVESTED WEIGHT	PRICE	INCOME
Harvest 2016 77.6 acre	1,925 ton	\$120.00 /ton	\$231,000.00
Nov 15, 2017			
Total	1,925 ton	\$120.00 /ton	\$231,000.00

Grandview 4

FIELD SUMMARY

Costs	Income	Gross Profit	Gross Margin
\$281.27 /acre Total: \$11,495.50	\$480.02 /acre Total: \$19,618.50	\$198.75 /acre Total: \$8,123.00	41.4 %

INCOME SUMMARY

AREA	YIELD	PRICE	OTHER INCOME	TOTAL INCOME
40.87 acre	110.35 bu/acre	\$4.35 /bu	\$0.00	\$19,618.50

COST SUMMARY

SEED	FERTILIZER	CHEMICALS	CONTRACTORS	OPERATIONS	OTHER COSTS	TOTAL COST
\$21.96 /acre	\$154.31 /acre	\$33.75 /acre	\$0.00 /acre	\$71.25 /acre	\$0.00 /acre	\$281.27 /acre

ROTATION HISTORY

2016

Wheat - winter

40.87 acre | Brundage 96

Active Ingredients: N 281.59 lbs/acre Phosphate 100.36 lbs/acre K2O 50.4 lbs/acre

ACTIVITIES

SITUATION/ TIMING	INPUTS	ACTIVE	APPLY	UNITS	COST / ACRE	COST
spring fertilizer 40.87 acre Mar 31, 2016 Broadcast	Andersons 46-0-0	Nitrogen	348 lbs/acre	14,222.76 lbs	\$56.55	\$2,311.20
	Agrium 11-52-0 MAP	Nitrogen and Phosphate	96 lbs/acre	3,923.52 lbs	\$22.32	\$912.22
	Fertilizer Application		1 acre/acre	40.87 acre	\$8.00	\$326.96
					Total	\$3,550.38
Planting 40.87 acre May 19, 2016	Alturas (wheat)		120 lbs/acre	4,904.4 lbs	\$12.00	\$490.44
	Planting		1 acre/acre	40.87 acre	\$6.00	\$245.22
					Total	\$735.66
Harvest 40.87 acre Aug 05, 2016	Mechanical harvesting		1 acre/acre	40.87 acre	\$10.00	\$408.70
					Total	\$408.70
Aerial Imagery 40.87 acre Oct 14, 2016	Field Scouting		1 acre/acre	40.87 acre	\$0.75	\$30.65
					Total	\$30.65
Irrigation 40.87 acre Oct 14, 2016	Irrigation		1 acre/acre	40.87 acre	\$10.00	\$408.70
					Total	\$408.70
Harvest 40.87 acre Oct 14, 2016	Harvest		1 acre/acre	40.87 acre	\$4.50	\$183.92
					Total	\$183.92
Planting 40.87 acre Oct 14, 2016	Planting		1 acre/acre	40.87 acre	\$4.00	\$163.48
	Brundage 96		120 lbs/acre	4,904.4 lbs	\$9.96	\$407.07
					Total	\$570.55

SITUATION/ TIMING	INPUTS	ACTIVE	APPLY	UNITS	COST / ACRE	COST
Ethephon 40.87 acre Oct 14, 2016 Aerial Spraying	Water Rate		640 floz/acre	204.35 gal		
	MANA Ethephon 2SL	Ethephon	1.5 pt/acre	7.66 gal	\$15.00	\$613.05
	Spray/aerial		1 acre/acre	40.87 acre	\$8.00	\$326.96
	Topaz	Propiconazole	4 floz/acre	1.28 gal	\$1.87	\$76.63
					Total	\$1,016.64
Herbicide Application 40.87 acre Oct 14, 2016 Self Propelled Boomspray	Water Rate		1,920 floz/acre	613.05 gal		
	Huskie Herbicide	Bromoxynil Octanoic Acid Ester, Pyrasulfotole, and Bromoxynil Heptanoate	15 floz/acre	4.79 gal	\$9.38	\$383.16
		Class Act NG	Ammonium sulfate, corn syrup, alkyl polyglycoside	16 floz/acre	5.11 gal	\$2.50
	DuPont Aproach Fungicide Spray/herbicide	Picoxystrobin (stobilurin)	4 floz/acre	1.28 gal	\$5.00	\$204.35
				1 acre/acre	40.87 acre	\$10.00
					Total	\$1,098.38
Spring Fertilizer 40.87 acre Oct 14, 2016 Spreader	Andersons 46-0-0	Nitrogen	218 lbs/acre	8,909.66 lbs	\$39.24	\$1,603.74
	Muriate of Potash 0-0-60	Potash	84 lbs/acre	3,433.08 lbs	\$16.80	\$686.62
	Agrium 11-52-0 MAP	Nitrogen and Phosphate	97 lbs/acre	3,964.39 lbs	\$19.40	\$792.88
	Spreading fertilizer		1 acre/acre	40.87 acre	\$10.00	\$408.70
					Total	\$3,491.93
					Total	\$0.00
					Total	\$11,495.50

HARVEST ACTIVITIES

SITUATION/TIMING	HARVESTED WEIGHT	PRICE	INCOME
Harvest 2016 40.87 acre Nov 15, 2017	4,510 bu	\$4.35 /bu	\$19,618.50
Total	4,510 bu	\$4.35 /bu	\$19,618.50

Grandview 5

FIELD SUMMARY

Costs	Income	Gross Profit	Gross Margin
\$165.65 /acre Total: \$37,001.24	\$486.69 /acre Total: \$108,713	\$321.04 /acre Total: \$71,711.26	65.96 %

INCOME SUMMARY

AREA	YIELD	PRICE	OTHER INCOME	TOTAL INCOME
223.37 acre	129.78 bu/acre	\$3.75 /bu	\$0.00	\$108,712.50

COST SUMMARY

SEED	FERTILIZER	CHEMICALS	CONTRACTORS	OPERATIONS	OTHER COSTS	TOTAL COST
\$9.96 /acre	\$75.44 /acre	\$33.75 /acre	\$0.00 /acre	\$46.50 /acre	\$0.00 /acre	\$165.65 /acre

ROTATION HISTORY

2016

Wheat - winter

223.37 acre | Brundage 96

Active Ingredients: N 110.95 lbs/acre Phosphate 50.44 lbs/acre K2O 50.4 lbs/acre

ACTIVITIES

SITUATION/ TIMING	INPUTS	ACTIVE	APPLY	UNITS	COST / ACRE	COST
Irrigation 223.37 acre Oct 14, 2016	Irrigation		1 acre/acre	223.37 acre	\$10.00	\$2,233.70
						Total \$2,233.70
Harvest 223.37 acre Oct 14, 2016	Harvest		1 acre/acre	223.37 acre	\$4.50	\$1,005.17
						Total \$1,005.17
Planting 223.37 acre Oct 14, 2016	Planting		1 acre/acre	223.37 acre	\$4.00	\$893.48
	Brundage 96		120 lbs/acre	26,804.4 lbs	\$9.96	\$2,224.77
						Total \$3,118.25
Ethephon 223.37 acre Oct 14, 2016 Aerial Spraying	Water Rate		640 floz/acre	1,116.85 gal		
	MANA Ethephon 2SL	Ethephon	1.5 pt/acre	41.88 gal	\$15.00	\$3,350.55
	Spray/aerial		1 acre/acre	223.37 acre	\$8.00	\$1,786.96
	Topaz	Propiconazole	4 floz/acre	6.98 gal	\$1.87	\$418.82
						Total \$5,556.33

SITUATION/ TIMING	INPUTS	ACTIVE	APPLY	UNITS	COST / ACRE	COST
Herbicide Application 223.37 acre Oct 14, 2016 Self Propelled Boomspray	Water Rate		1,920 floz/acre	3,350.55 gal		
	Huskie Herbicide	Bromoxynil Octanoic Acid Ester, Pyrasulfotole, and Bromoxynil Heptanoate	15 floz/acre	26.18 gal	\$9.38	\$2,094.09
	Class Act NG	Ammonium sulfate, corn syrup, alkyl polyglycoside	16 floz/acre	27.92 gal	\$2.50	\$558.43
	DuPont Aproach Fungicide	Picoxystrobin (stobilurin)	4 floz/acre	6.98 gal	\$5.00	\$1,116.85
	Spray/herbicide		1 acre/acre	223.37 acre	\$10.00	\$2,233.70
					Total	\$6,003.07
Spring Fertilizer 223.37 acre Oct 14, 2016 Spreader	Andersons 46-0-0	Nitrogen	218 lbs/acre	48,694.66 lbs	\$39.24	\$8,765.04
	Muriate of Potash 0-0-60	Potash	84 lbs/acre	18,763.08 lbs	\$16.80	\$3,752.62
	Agrium 11-52-0 MAP	Nitrogen and Phosphate	97 lbs/acre	21,666.89 lbs	\$19.40	\$4,333.38
	Spreading fertilizer		1 acre/acre	223.37 acre	\$10.00	\$2,233.70
					Total	\$19,084.73
					Total	\$0.00
					Total	\$37,001.24

HARVEST ACTIVITIES

SITUATION/TIMING	HARVESTED WEIGHT	PRICE	INCOME
Harvest 2016 223.37 acre Nov 15, 2017	28,990 bu	\$3.75 /bu	\$108,712.50
Total	28,990 bu	\$3.75 /bu	\$108,712.50

Highway 39 Aerial Overview

Potato ■ Sugar Beet ■

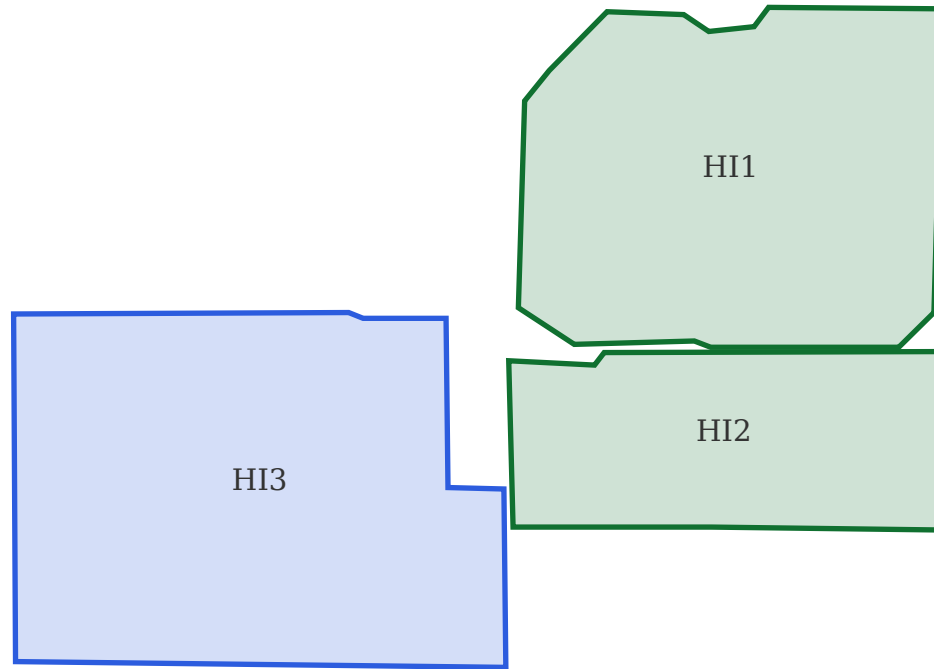

GROSS PROFIT BY ROTATION HISTORY - Highway 39

FIELD	2016
Highway 1 (Map : HI1)	Sugar Beet BTS 20RR28 \$1,310.98 /acre
Highway 2 (Map : HI2)	Sugar Beet Crystal A399NT \$1,294.92 /acre
Highway 3 (Map : HI3)	Potato Russet Burbank \$-497.85 /acre

Highway 1

FIELD SUMMARY

Costs	Income	Gross Profit	Gross Margin
\$289.02 /acre Total: \$36,986.50	\$1,600.00 /acre Total: \$204,752	\$1,310.98 /acre Total: \$167,766	81.94 %

INCOME SUMMARY

AREA	YIELD	PRICE	OTHER INCOME	TOTAL INCOME
127.97 acre	40 ton/acre	\$40.00 /ton	\$0.00	\$204,752.00

COST SUMMARY

SEED	FERTILIZER	CHEMICALS	CONTRACTORS	OPERATIONS	OTHER COSTS	TOTAL COST
\$70.00 /acre	\$56.31 /acre	\$46.71 /acre	\$0.00 /acre	\$116.00 /acre	\$0.00 /acre	\$289.02 /acre

ROTATION HISTORY

2016

Sugar Beet

127.97 acre | BTS 20RR28

Active Ingredients: N 79.63 lbs/acre

ACTIVITIES

SITUATION/ TIMING	INPUTS	ACTIVE	APPLY	UNITS	COST / ACRE	COST
Sugar Beet Fertilizer 127.97 acre Oct 14, 2016	Valley Agronomics 32-0-0	Nitrogen	22.5 gal/acre	2,879.33 gal	\$56.31	\$7,206.60
					Total	\$7,206.60
Irrigation 127.97 acre Oct 14, 2016	Irrigation		1 acre/acre	127.97 acre	\$15.00	\$1,919.55
					Total	\$1,919.55
Sugar Beet Harvest 127.97 acre Oct 14, 2016	Harvest		1 acre/acre	127.97 acre	\$50.00	\$6,398.50
					Total	\$6,398.50
Sugar Beets-Fungicide-Topaz, Micronized Sulfur, Masterlock 127.97 acre Oct 14, 2016 Aerial Spraying	Topaz UPI Microthiol Disperss	Propiconazole Sulfur	4 floz/acre 2 lbs/acre	4 gal 255.94 lbs	\$2.66 \$7.46	\$339.92 \$954.66
	Masterlock	Modified vegetable oil, polyoxyethylene sorbitan fatty acid ester, vegetable oil, and soybean oil, ethoxylated	6 floz/acre	6 gal	\$1.27	\$161.96
	Spray/aerial		1 acre/acre	127.97 acre	\$10.00	\$1,279.70
					Total	\$2,736.24

SITUATION/ TIMING	INPUTS	ACTIVE	APPLY	UNITS	COST / ACRE	COST
Sugar Beets- Herbicide/ Insecticide- Round-Up PM, Class Act NG, Clorpyrifos 4E, Interlock 127.97 acre Oct 14, 2016 Broadcast	Water Rate		1,280 floz/acre	1,279.7 gal		
	Roundup PowerMAX Herbicide	Glyphosate as the Potassium Salt	32 floz/acre	31.99 gal	\$6.50	\$831.81
	Class Act NG	Ammonium sulfate, corn syrup, alkyl polyglycoside	16 floz/acre	16 gal	\$1.75	\$223.95
	Arysta Chlorpyrifos 4E AG	Chlorpyrifos	1.5 pt/acre	23.99 gal	\$11.44	\$1,463.66
	InterLock	Modified vegetable oil, polyoxyethylene sorbitan fatty acid ester, vegetable oil	4 floz/acre	4 gal	\$2.06	\$263.94
	Boomspray application		1 acre/acre	127.97 acre	\$8.00	\$1,023.76
					Total	\$3,807.11
Sugar Beets- Herbicide/ Insecticide- Round Up Power Max, Stallion, Class Act, Interlock 127.97 acre Oct 14, 2016 Boomspray	Roundup PowerMAX Herbicide	Glyphosate as the Potassium Salt	24 floz/acre	23.99 gal	\$4.88	\$623.85
	Stallion EC Insecticide	Zeta-cypermethrin and Chlorpyrifos	8.5 floz/acre	8.5 gal	\$6.64	\$849.80
	Class Act NG	Ammonium sulfate, corn syrup, alkyl polyglycoside	2.5 gal/100gal	0 gal	\$0.00	\$0.00
	InterLock	Modified vegetable oil, polyoxyethylene sorbitan fatty acid ester, vegetable oil	4 floz/acre	4 gal	\$2.06	\$263.94
		Boomspray application		1 acre/acre	127.97 acre	\$8.00
					Total	\$2,761.35
Planting 127.97 acre Oct 14, 2016	Planting		1 acre/acre	127.97 acre	\$25.00	\$3,199.25
	BTS 20RR28		140 lbs/acre	17,915.8 lbs	\$70.00	\$8,957.90
					Total	\$12,157.15
					Total	\$0.00
					Total	\$36,986.50

HARVEST ACTIVITIES

SITUATION/TIMING	HARVESTED WEIGHT	PRICE	INCOME
Harvest 2016 127.97 acre Nov 15, 2017	5,118.8 ton	\$40.00 /ton	\$204,752.00
Total	5,118.8 ton	\$40.00 /ton	\$204,752.00

Highway 2

FIELD SUMMARY

Costs	Income	Gross Profit	Gross Margin
\$293.22 /acre Total: \$20,974.37	\$1,588.14 /acre Total: \$113,600.00	\$1,294.92 /acre Total: \$92,625.63	81.54 %

INCOME SUMMARY

AREA	YIELD	PRICE	OTHER INCOME	TOTAL INCOME
71.53 acre	39.7 ton/acre	\$40.00 /ton	\$0.00	\$113,600.00

COST SUMMARY

SEED	FERTILIZER	CHEMICALS	CONTRACTORS	OPERATIONS	OTHER COSTS	TOTAL COST
\$74.20 /acre	\$56.31 /acre	\$46.71 /acre	\$0.00 /acre	\$116.00 /acre	\$0.00 /acre	\$293.22 /acre

ROTATION HISTORY

2016

Sugar Beet

71.53 acre | Crystal A399NT

Active Ingredients: N 79.63 lbs/acre

ACTIVITIES

SITUATION/ TIMING	INPUTS	ACTIVE	APPLY	UNITS	COST / ACRE	COST
Sugar Beet Fertilizer 71.53 acre Oct 14, 2016	Valley Agronomics 32-0-0	Nitrogen	22.5 gal/acre	1,609.43 gal	\$56.31	\$4,028.19
					Total	\$4,028.19
Irrigation 71.53 acre Oct 14, 2016	Irrigation		1 acre/acre	71.53 acre	\$15.00	\$1,072.95
					Total	\$1,072.95
Sugar Beet Harvest 71.53 acre Oct 14, 2016	Harvest		1 acre/acre	71.53 acre	\$50.00	\$3,576.50
					Total	\$3,576.50
Sugar Beets-Fungicide-Topaz, Micronized Sulfur, Masterlock 71.53 acre Oct 14, 2016	Topaz UPI Microthiol Disperss	Propiconazole Sulfur	4 floz/acre 2 lbs/acre	2.24 gal 143.06 lbs	\$2.66 \$7.46	\$190.00 \$533.61
Masterlock 71.53 acre Oct 14, 2016	Masterlock	Modified vegetable oil, polyoxyethylene sorbitan fatty acid ester, vegetable oil, and soybean oil, ethoxylated	6 floz/acre	3.35 gal	\$1.27	\$90.53
Aerial Spraying	Spray/aerial		1 acre/acre	71.53 acre	\$10.00	\$715.30
					Total	\$1,529.45

SITUATION/ TIMING	INPUTS	ACTIVE	APPLY	UNITS	COST / ACRE	COST
Sugar Beets- Herbicide/ Insecticide- Round-Up PM, Class Act NG, Clorpyrifos 4E, Interlock 71.53 acre Oct 14, 2016 Broadcast	Water Rate		1,280 floz/acre	715.3 gal		
	Roundup PowerMAX Herbicide	Glyphosate as the Potassium Salt	32 floz/acre	17.88 gal	\$6.50	\$464.95
	Class Act NG	Ammonium sulfate, corn syrup, alkyl polyglycoside	16 floz/acre	8.94 gal	\$1.75	\$125.18
	Arysta Chlorpyrifos 4E AG	Chlorpyrifos	1.5 pt/acre	13.41 gal	\$11.44	\$818.12
	InterLock	Modified vegetable oil, polyoxyethylene sorbitan fatty acid ester, vegetable oil	4 floz/acre	2.24 gal	\$2.06	\$147.53
	Boomspray application		1 acre/acre	71.53 acre	\$8.00	\$572.24
					Total	\$2,128.02
Sugar Beets- Herbicide/ Insecticide- Round Up Power Max, Stallion, Class Act, Interlock 71.53 acre Oct 14, 2016 Boomspray	Roundup PowerMAX Herbicide	Glyphosate as the Potassium Salt	24 floz/acre	13.41 gal	\$4.88	\$348.71
	Stallion EC Insecticide	Zeta-cypermethrin and Chlorpyrifos	8.5 floz/acre	4.75 gal	\$6.64	\$475.00
	Class Act NG	Ammonium sulfate, corn syrup, alkyl polyglycoside	2.5 gal/100gal	0 gal	\$0.00	\$0.00
	InterLock	Modified vegetable oil, polyoxyethylene sorbitan fatty acid ester, vegetable oil	4 floz/acre	2.24 gal	\$2.06	\$147.53
	Boomspray application		1 acre/acre	71.53 acre	\$8.00	\$572.24
					Total	\$1,543.48
Planting 71.53 acre Oct 14, 2016	Crystal A399NT		140 lbs/acre	10,014.2 lbs	\$74.20	\$5,307.53
	Planting		1 acre/acre	71.53 acre	\$25.00	\$1,788.25
					Total	\$7,095.78
					Total	\$0.00
					Total	\$20,974.37

HARVEST ACTIVITIES

SITUATION/TIMING	HARVESTED WEIGHT	PRICE	INCOME
Harvest 2016 71.53 acre Nov 15, 2017	2,840 ton	\$40.00 /ton	\$113,600.00
Total	2,840 ton	\$40.00 /ton	\$113,600.00

Highway 3

FIELD SUMMARY

Costs	Income	Gross Profit	Gross Margin
\$1,195.42 /acre Total: \$185,935	\$697.57 /acre Total: \$108,500.00	\$-497.85 /acre Total: \$-77,435.28	-71.37 %

INCOME SUMMARY

AREA	YIELD	PRICE	OTHER INCOME	TOTAL INCOME
155.54 acre	24.91 ton/acre	\$28.00 /ton	\$0.00	\$108,500.00

COST SUMMARY

SEED	FERTILIZER	CHEMICALS	CONTRACTORS	OPERATIONS	OTHER COSTS	TOTAL COST
\$2.52 /acre	\$554.10 /acre	\$429.80 /acre	\$0.00 /acre	\$209.00 /acre	\$0.00 /acre	\$1,195.42 /acre

ROTATION HISTORY

2016

Potato

155.54 acre | Russet Burbank

Active Ingredients: N 357.35 lbs/acre Phosphate 209.65 lbs/acre K2O 0.2 lbs/acre Potash 110.46 lbs/acre S 425.3 lbs/acre Mg 10.04 lbs/acre Mn 2 lbs/acre Zn 8.15 lbs/acre Organic acids including Humic and Fulvic 5.32 lbs/acre

ACTIVITIES

SITUATION/ TIMING	INPUTS	ACTIVE	APPLY	UNITS	COST / ACRE	COST
Potato Irrigation/ Fertigation 155.54 acre Oct 14, 2016 Fertigation	Irrigation		1 acre/acre	155.54 acre	\$15.00	\$2,333.10
	Valley Agronomics 32-0-0	Nitrogen	55 gal/acre	8,554.7 gal	\$137.66	\$21,411.37
	Thio-Sul (12-0-0-26S)	Sulfur and Nitrogen	18.15 gal/acre	2,823.05 gal	\$40.82	\$6,348.65
	Actagro Structure 7-21-0	Organic acids including Humic and Fulvic, Nitrogen, Phosphate, and Zinc	7 gal/acre	1,088.78 gal	\$56.00	\$8,710.24
					Total	\$38,803.36
Potato Spring Fertilizer 155.54 acre Oct 14, 2016 Fertilizer Application	Valley 21-0-0-24s	Nitrogen and Sulfur	380 lbs/acre	59,105.2 lbs	\$57.46	\$8,936.71
	Variable Rate Ground - spreading 1		1 acre/acre	155.54 acre	\$10.00	\$1,555.40
					Total	\$10,492.11

SITUATION/ TIMING	INPUTS	ACTIVE	APPLY	UNITS	COST / ACRE	COST
Potato Fall Fertilizer 155.54 acre Oct 14, 2016 Fertilizer Application	Valley 12-45-0-5-1Z	Sulfur, Nitrogen, Phosphate, and Zinc	302 lbs/acre	46,973.08 lbs	\$82.26	\$12,795.47
	Valley 0-0-60	Potash	150 lbs/acre	23,331 lbs	\$25.92	\$4,031.60
	K-Mag	Potash, Magnesium, and Sulfur	93 lbs/acre	14,465.22 lbs	\$25.44	\$3,957.68
	Elemental Sulphur 85%	Sulfur	117 lbs/acre	18,198.18 lbs	\$27.38	\$4,258.37
	Power Zinc 35 Granular	Sulfur and Zinc	14 lbs/acre	2,177.56 lbs	\$7.93	\$1,233.37
	Agfinity Manganese Sulfate 32%	Sulfur and Manganese	6.25 lbs/acre	972.13 lbs	\$4.61	\$717.43
	Variable Rate Ground - spreading 1		1 acre/acre	155.54 acre	\$14.00	\$2,177.56
					Total	\$29,171.48
Potato Prep Fumigation 155.54 acre Oct 14, 2016 Soil Shank Injection	Vapam HL Soil Fumigant	Metam-Sodium	40 gal/acre	6,221.6 gal	\$240.00	\$37,329.60
	Deep Ripping		1 acre/acre	155.54 acre	\$40.00	\$6,221.60
					Total	\$43,551.20
Stubble Digest Sulfuric Acid 155.54 acre Oct 14, 2016 Boomspray	Sulfuric Acid	Sulfur	30 gal/acre	4,666.2 gal	\$27.00	\$4,199.58
	Boomspray - contract		1 acre/acre	155.54 acre	\$12.00	\$1,866.48
					Total	\$6,066.06
Potatoes-Fungicide/Insecticide-Zing!, Abba Ultra, Masterlock 155.54 acre Oct 14, 2016 Aerial Spraying	Zing!	Zoxamide and Chlorothalonil	1 qt/acre	38.88 gal	\$17.50	\$2,721.95
	ABBA Ultra	Abamectin	8 floz/acre	9.72 gal	\$6.56	\$1,020.73
	Masterlock	Modified vegetable oil, polyoxyethylene sorbitan fatty acid ester, vegetable oil, and soybean oil, ethoxylated	6 floz/acre	7.29 gal	\$1.17	\$182.27
	Spray/aerial		1 acre/acre	155.54 acre	\$10.00	\$1,555.40
					Total	\$5,480.35
Potato Harvest 155.54 acre Oct 14, 2016	Harvest		1 acre/acre	155.54 acre	\$50.00	\$7,777.00
					Total	\$7,777.00
Potatoes-Desiccant-Reglone, Parazone, Aduro 155.54 acre Oct 14, 2016 Self Propelled Boomspray	Water Rate		2,560 floz/acre	3,110.8 gal		
	Reglone Desiccant	Diquat as the diquat dibromide	2 pt/acre	38.88 gal	\$23.25	\$3,616.31
	Parazone 3SL	Paraquat Dichloride	1 pt/acre	19.44 gal	\$3.75	\$583.27
	Aduro	Monocarbamide dihydrogen sulfate, alkyl amine ethoxylate, 1,2,3-trihydroxypropane	2 pt/100gal	7.78 gal	\$1.10	\$171.09
	Boomspray application		1 acre/acre	155.54 acre	\$8.00	\$1,244.32
					Total	\$5,614.99
Potato Seed Cutting 155.54 acre Oct 14, 2016	Seed - Treatment		1 acre/acre	155.54 acre	\$1.00	\$155.54
	Advise Four Flowable Insecticide	Imidacloprid	4 floz/100lb	0 gal	\$0.00	\$0.00
	Power-Line Potato Seed Treat Mancozeb 6% Plus Bark	Mancozeb	0.75 lbs/100lb	0 lbs	\$0.00	\$0.00
					Total	\$155.54

SITUATION/ TIMING	INPUTS	ACTIVE	APPLY	UNITS	COST / ACRE	COST
White Mold/ Early Blight Application 155.54 acre Oct 14, 2016 Self Propelled Boomspray	Luna Tranquility	Fluopyram and Pyrimethanil	11 floz/acre	13.37 gal	\$34.38	\$5,346.69
	Boomspray application		1 acre/acre	155.54 acre	\$8.00	\$1,244.32
					Total	\$6,591.01
White Mold/ Early Blight 155.54 acre Oct 14, 2016 Boomspray	Endura Fungicide	Boscalid	6 oz/acre	58.33 lbs	\$33.60	\$5,226.14
	UPI Manzate Pro Stick	Mancozeb	1 lbs/acre	155.54 lbs	\$5.70	\$886.58
	Boomspray application		1 acre/acre	155.54 acre	\$8.00	\$1,244.32
					Total	\$7,357.04
Potato Herbicide 155.54 acre Oct 14, 2016 Self Propelled Boomspray	Prowl H2O Herbicide	Pendimethalin	1.5 pt/acre	29.16 gal	\$9.00	\$1,399.86
	Boundary 6.5 EC Herbicide	Metribuzin and S- Metolachlor	2 pt/acre	38.88 gal	\$22.50	\$3,499.65
	Dimetric DF 75%	Metribuzin	0.33 lbs/acre	51.33 lbs	\$4.29	\$667.27
	Boomspray application		1 acre/acre	155.54 acre	\$8.00	\$1,244.32
					Total	\$6,811.10
Potato Planting 155.54 acre Oct 14, 2016	Planting		1 acre/acre	155.54 acre	\$25.00	\$3,888.50
	Russet Burbank		28 lbs/acre	4,355.12 lbs	\$2.52	\$391.96
	Valley Agronomics 11-37-0	Phosphate and Nitrogen	13 gal/acre	2,022.02 gal	\$53.37	\$8,300.80
	Actagro Liquid Humus 0-0-4	Potash	2 qt/acre	77.77 gal	\$7.50	\$1,166.55
	Winfield Liquid Zinc 7%	Sulfur and Zinc	1 pt/acre	19.44 gal	\$0.75	\$116.65
	Moncut 70-DF	Flutolanil	0.75 lbs/acre	116.65 lbs	\$27.00	\$4,199.58
					Total	\$18,064.04
					Total	\$0.00
					Total	\$185,935.28

HARVEST ACTIVITIES

SITUATION/TIMING	HARVESTED WEIGHT	PRICE	INCOME
Harvest 2016 155.54 acre Nov 15, 2017	3,875 ton	\$28.00 /ton	\$108,500.00
Total	3,875 ton	\$28.00 /ton	\$108,500.00

Springfield Aerial Overview

Alfalfa  Sugar Beet  Wheat - winter 

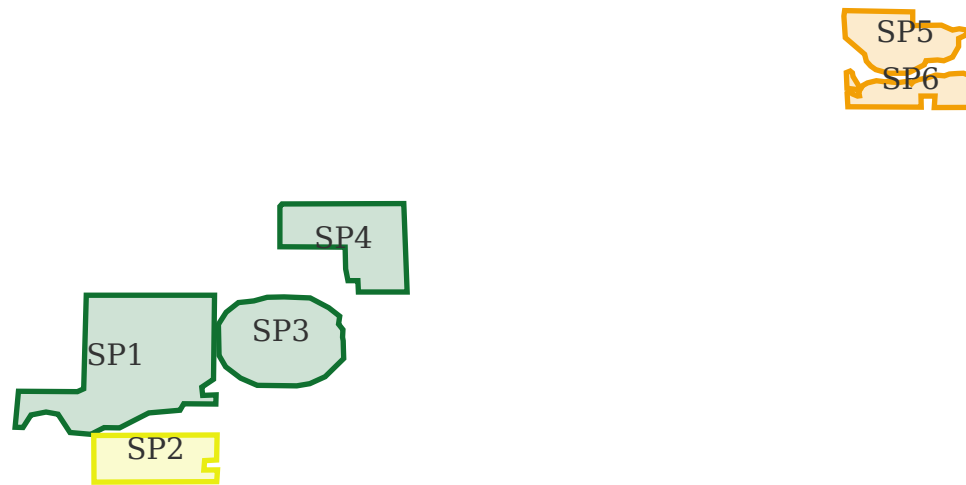

GROSS PROFIT BY ROTATION HISTORY - Springfield

FIELD	2016
Springfield 1 (Map : SP1)	Sugar Beet BTS 20RR28 \$1,264.79 /acre
Springfield 2 (Map : SP2)	Wheat - winter Brundage 96 \$299.35 /acre
Springfield 3 (Map : SP3)	Sugar Beet BTS 20RR28 \$1,224.49 /acre
Springfield 4 (Map : SP4)	Sugar Beet BTS 20RR28 \$1,459.31 /acre
Springfield 5 (Map : SP5)	Alfalfa LegenDairy XHD \$286.07 /acre
Springfield 6 (Map : SP6)	Alfalfa LegenDairy XHD \$248.53 /acre

Springfield 1

FIELD SUMMARY

Costs	Income	Gross Profit	Gross Margin
\$289.02 /acre Total: \$68,481.53	\$1,553.81 /acre Total: \$368,160.00	\$1,264.79 /acre Total: \$299,678	81.4 %

INCOME SUMMARY

AREA	YIELD	PRICE	OTHER INCOME	TOTAL INCOME
236.94 acre	38.85 ton/acre	\$40.00 /ton	\$0.00	\$368,160.00

COST SUMMARY

SEED	FERTILIZER	CHEMICALS	CONTRACTORS	OPERATIONS	OTHER COSTS	TOTAL COST
\$70.00 /acre	\$56.31 /acre	\$46.71 /acre	\$0.00 /acre	\$116.00 /acre	\$0.00 /acre	\$289.02 /acre

ROTATION HISTORY

2016

Sugar Beet

236.94 acre | BTS 20RR28

Active Ingredients: N 79.63 lbs/acre

ACTIVITIES

SITUATION/ TIMING	INPUTS	ACTIVE	APPLY	UNITS	COST / ACRE	COST
Sugar Beet Fertilizer 236.94 acre Oct 14, 2016	Valley Agronomics 32-0-0	Nitrogen	22.5 gal/acre	5,331.15 gal	\$56.31	\$13,343.22
						Total \$13,343.22
Irrigation 236.94 acre Oct 14, 2016	Irrigation		1 acre/acre	236.94 acre	\$15.00	\$3,554.10
						Total \$3,554.10
Sugar Beet Harvest 236.94 acre Oct 14, 2016	Harvest		1 acre/acre	236.94 acre	\$50.00	\$11,847.00
						Total \$11,847.00
Sugar Beets-Fungicide-Topaz, Micronized Sulfur, Masterlock 236.94 acre Oct 14, 2016 Aerial Spraying	Topaz UPI Microthiol Disperss	Propiconazole Sulfur	4 floz/acre 2 lbs/acre	7.4 gal 473.88 lbs	\$2.66 \$7.46	\$629.37 \$1,767.57
	Masterlock	Modified vegetable oil, polyoxyethylene sorbitan fatty acid ester, vegetable oil, and soybean oil, ethoxylated	6 floz/acre	11.11 gal	\$1.27	\$299.88
	Spray/aerial		1 acre/acre	236.94 acre	\$10.00	\$2,369.40
						Total \$5,066.22

SITUATION/ TIMING	INPUTS	ACTIVE	APPLY	UNITS	COST / ACRE	COST
Sugar Beets- Herbicide/ Insecticide- Round-Up PM, Class Act NG, Chlorpyrifos 4E, Interlock 236.94 acre Oct 14, 2016 Broadcast	Water Rate		1,280 floz/acre	2,369.4 gal		
	Roundup PowerMAX Herbicide	Glyphosate as the Potassium Salt	32 floz/acre	59.24 gal	\$6.50	\$1,540.11
	Class Act NG	Ammonium sulfate, corn syrup, alkyl polyglycoside	16 floz/acre	29.62 gal	\$1.75	\$414.65
	Arysta Chlorpyrifos 4E AG	Chlorpyrifos	1.5 pt/acre	44.43 gal	\$11.44	\$2,710.00
	InterLock	Modified vegetable oil, polyoxyethylene sorbitan fatty acid ester, vegetable oil	4 floz/acre	7.4 gal	\$2.06	\$488.69
	Boomspray application		1 acre/acre	236.94 acre	\$8.00	\$1,895.52
					Total	\$7,048.97
Sugar Beets- Herbicide/ Insecticide- Round Up Power Max, Stallion, Class Act, Interlock 236.94 acre Oct 14, 2016 Boomspray	Roundup PowerMAX Herbicide	Glyphosate as the Potassium Salt	24 floz/acre	44.43 gal	\$4.87	\$1,155.08
	Stallion EC Insecticide	Zeta-cypermethrin and Chlorpyrifos	8.5 floz/acre	15.73 gal	\$6.64	\$1,573.43
	Class Act NG	Ammonium sulfate, corn syrup, alkyl polyglycoside	2.5 gal/100gal	0 gal	\$0.00	\$0.00
	InterLock	Modified vegetable oil, polyoxyethylene sorbitan fatty acid ester, vegetable oil	4 floz/acre	7.4 gal	\$2.06	\$488.69
		Boomspray application		1 acre/acre	236.94 acre	\$8.00
					Total	\$5,112.72
Planting 236.94 acre Oct 14, 2016	Planting		1 acre/acre	236.94 acre	\$25.00	\$5,923.50
	BTS 20RR28		140 lbs/acre	33,171.6 lbs	\$70.00	\$16,585.80
					Total	\$22,509.30
					Total	\$0.00
					Total	\$68,481.53

HARVEST ACTIVITIES

SITUATION/TIMING	HARVESTED WEIGHT	PRICE	INCOME
Harvest 2016 236.94 acre Nov 15, 2017	9,204 ton	\$40.00 /ton	\$368,160.00
Total	9,204 ton	\$40.00 /ton	\$368,160.00

Springfield 2

FIELD SUMMARY

Costs	Income	Gross Profit	Gross Margin
\$165.65 /acre Total: \$12,423.75	\$465.00 /acre Total: \$34,875.00	\$299.35 /acre Total: \$22,451.25	64.38 %

INCOME SUMMARY

AREA	YIELD	PRICE	OTHER INCOME	TOTAL INCOME
75 acre	124 bu/acre	\$3.75 /bu	\$0.00	\$34,875.00

COST SUMMARY

SEED	FERTILIZER	CHEMICALS	CONTRACTORS	OPERATIONS	OTHER COSTS	TOTAL COST
\$9.96 /acre	\$75.44 /acre	\$33.75 /acre	\$0.00 /acre	\$46.50 /acre	\$0.00 /acre	\$165.65 /acre

ROTATION HISTORY

2016

Wheat - winter

75 acre | Brundage 96

Active Ingredients: N 110.95 lbs/acre Phosphate 50.44 lbs/acre K2O 50.4 lbs/acre

ACTIVITIES

SITUATION/ TIMING	INPUTS	ACTIVE	APPLY	UNITS	COST / ACRE	COST
Irrigation 75 acre Oct 14, 2016	Irrigation		1 acre/acre	75 acre	\$10.00	\$750.00
						Total \$750.00
Harvest 75 acre Oct 14, 2016	Harvest		1 acre/acre	75 acre	\$4.50	\$337.50
						Total \$337.50
Planting 75 acre Oct 14, 2016	Planting		1 acre/acre	75 acre	\$4.00	\$300.00
	Brundage 96		120 lbs/acre	9,000 lbs	\$9.96	\$747.00
						Total \$1,047.00
Ethephon 75 acre Oct 14, 2016	Water Rate		640 floz/acre	375 gal		
	MANA Ethephon 2SL	Ethephon	1.5 pt/acre	14.06 gal	\$15.00	\$1,125.00
	Spray/aerial		1 acre/acre	75 acre	\$8.00	\$600.00
	Aerial Spraying	Propiconazole	4 floz/acre	2.34 gal	\$1.87	\$140.63
						Total \$1,865.63
Herbicide Application 75 acre Oct 14, 2016	Water Rate		1,920 floz/acre	1,125 gal		
	Huskie Herbicide	Bromoxynil Octanoic Acid Ester, Pyrasulfotole, and Bromoxynil Heptanoate	15 floz/acre	8.79 gal	\$9.38	\$703.13
	Class Act NG	Ammonium sulfate, corn syrup, alkyl polyglycoside	16 floz/acre	9.38 gal	\$2.50	\$187.50
	DuPont Aproach Fungicide	Picoxystrobin (stobilurin)	4 floz/acre	2.34 gal	\$5.00	\$375.00
	Spray/herbicide		1 acre/acre	75 acre	\$10.00	\$750.00
						Total \$2,015.63

SITUATION/ TIMING	INPUTS	ACTIVE	APPLY	UNITS	COST / ACRE	COST
Spring Fertilizer 75 acre Oct 14, 2016 Spreader	Andersons 46-0-0	Nitrogen	218 lbs/acre	16,350 lbs	\$39.24	\$2,943.00
	Muriate of Potash 0-0-60	Potash	84 lbs/acre	6,300 lbs	\$16.80	\$1,260.00
	Agrium 11-52-0 MAP	Nitrogen and Phosphate	97 lbs/acre	7,275 lbs	\$19.40	\$1,455.00
	Spreading fertilizer		1 acre/acre	75 acre	\$10.00	\$750.00
					Total	\$6,408.00
					Total	\$0.00
					Total	\$12,423.75

HARVEST ACTIVITIES

SITUATION/TIMING	HARVESTED WEIGHT	PRICE	INCOME
Harvest 2016 75 acre Nov 15, 2017	9,300 bu	\$3.75 /bu	\$34,875.00
Total	9,300 bu	\$3.75 /bu	\$34,875.00

Springfield 3

FIELD SUMMARY

Costs	Income	Gross Profit	Gross Margin
\$289.02 /acre Total: \$36,573.19	\$1,513.51 /acre Total: \$191,520.00	\$1,224.49 /acre Total: \$154,947	80.9 %

INCOME SUMMARY

AREA	YIELD	PRICE	OTHER INCOME	TOTAL INCOME
126.54 acre	37.84 ton/acre	\$40.00 /ton	\$0.00	\$191,520.00

COST SUMMARY

SEED	FERTILIZER	CHEMICALS	CONTRACTORS	OPERATIONS	OTHER COSTS	TOTAL COST
\$70.00 /acre	\$56.31 /acre	\$46.71 /acre	\$0.00 /acre	\$116.00 /acre	\$0.00 /acre	\$289.02 /acre

ROTATION HISTORY

2016

Sugar Beet

126.54 acre | BTS 20RR28

Active Ingredients: N 79.63 lbs/acre

ACTIVITIES

SITUATION/ TIMING	INPUTS	ACTIVE	APPLY	UNITS	COST / ACRE	COST
Sugar Beet Fertilizer 126.54 acre Oct 14, 2016	Valley Agronomics 32-0-0	Nitrogen	22.5 gal/acre	2,847.15 gal	\$56.31	\$7,126.07
					Total	\$7,126.07
Irrigation 126.54 acre Oct 14, 2016	Irrigation		1 acre/acre	126.54 acre	\$15.00	\$1,898.10
					Total	\$1,898.10
Sugar Beet Harvest 126.54 acre Oct 14, 2016	Harvest		1 acre/acre	126.54 acre	\$50.00	\$6,327.00
					Total	\$6,327.00
Sugar Beets-Fungicide-Topaz, Micronized Sulfur, Masterlock 126.54 acre Oct 14, 2016 Aerial Spraying	Topaz UPI Microthiol Disperss	Propiconazole Sulfur	4 floz/acre 2 lbs/acre	3.95 gal 253.08 lbs	\$2.66 \$7.46	\$336.12 \$943.99
	Masterlock	Modified vegetable oil, polyoxyethylene sorbitan fatty acid ester, vegetable oil, and soybean oil, ethoxylated	6 floz/acre	5.93 gal	\$1.27	\$160.15
	Spray/aerial		1 acre/acre	126.54 acre	\$10.00	\$1,265.40
					Total	\$2,705.66

SITUATION/ TIMING	INPUTS	ACTIVE	APPLY	UNITS	COST / ACRE	COST
Sugar Beets- Herbicide/ Insecticide- Round-Up PM, Class Act NG, Clorpyrifos 4E, Interlock 126.54 acre Oct 14, 2016 Broadcast	Water Rate		1,280 floz/acre	1,265.4 gal		
	Roundup PowerMAX Herbicide	Glyphosate as the Potassium Salt	32 floz/acre	31.64 gal	\$6.50	\$822.51
	Class Act NG	Ammonium sulfate, corn syrup, alkyl polyglycoside	16 floz/acre	15.82 gal	\$1.75	\$221.45
	Arysta Chlorpyrifos 4E AG	Chlorpyrifos	1.5 pt/acre	23.73 gal	\$11.44	\$1,447.30
	InterLock	Modified vegetable oil, polyoxyethylene sorbitan fatty acid ester, vegetable oil	4 floz/acre	3.95 gal	\$2.06	\$260.99
	Boomspray application		1 acre/acre	126.54 acre	\$8.00	\$1,012.32
					Total	\$3,764.57
Sugar Beets- Herbicide/ Insecticide- Round Up Power Max, Stallion, Class Act, Interlock 126.54 acre Oct 14, 2016 Boomspray	Roundup PowerMAX Herbicide	Glyphosate as the Potassium Salt	24 floz/acre	23.73 gal	\$4.88	\$616.88
	Stallion EC Insecticide	Zeta-cypermethrin and Chlorpyrifos	8.5 floz/acre	8.4 gal	\$6.64	\$840.30
	Class Act NG	Ammonium sulfate, corn syrup, alkyl polyglycoside	2.5 gal/100gal	0 gal	\$0.00	\$0.00
	InterLock	Modified vegetable oil, polyoxyethylene sorbitan fatty acid ester, vegetable oil	4 floz/acre	3.95 gal	\$2.06	\$260.99
		Boomspray application		1 acre/acre	126.54 acre	\$8.00
					Total	\$2,730.50
Planting 126.54 acre Oct 14, 2016	Planting		1 acre/acre	126.54 acre	\$25.00	\$3,163.50
	BTS 20RR28		140 lbs/acre	17,715.6 lbs	\$70.00	\$8,857.80
					Total	\$12,021.30
					Total	\$0.00
					Total	\$36,573.19

HARVEST ACTIVITIES

SITUATION/TIMING	HARVESTED WEIGHT	PRICE	INCOME
Harvest 2016 126.54 acre Nov 15, 2017	4,788 ton	\$40.00 /ton	\$191,520.00
Total	4,788 ton	\$40.00 /ton	\$191,520.00

Springfield 4

FIELD SUMMARY

Costs	Income	Gross Profit	Gross Margin
\$217.71 /acre Total: \$23,336.33	\$1,677.02 /acre Total: \$179,760.00	\$1,459.31 /acre Total: \$156,424	87.02 %

INCOME SUMMARY

AREA	YIELD	PRICE	OTHER INCOME	TOTAL INCOME
107.19 acre	41.93 ton/acre	\$40.00 /ton	\$0.00	\$179,760.00

COST SUMMARY

SEED	FERTILIZER	CHEMICALS	CONTRACTORS OPERATIONS	OTHER COSTS	TOTAL COST
\$70.00 /acre	\$0.00 /acre	\$46.71 /acre	\$0.00 /acre	\$0.00 /acre	\$217.71 /acre

ROTATION HISTORY

2016

Sugar Beet

107.19 acre | BTS 20RR28

ACTIVITIES

SITUATION/ TIMING	INPUTS	ACTIVE	APPLY	UNITS	COST / ACRE	COST
Sugar Beets- Herbicide/ Insecticide- Round Up Power Max, Stallion, Class Act, Interlock 107.19 acre Oct 14, 2016 Boomspray	Roundup PowerMAX Herbicide	Glyphosate as the Potassium Salt	24 floz/acre	20.1 gal	\$4.88	\$522.55
	Stallion EC Insecticide	Zeta-cypermethrin and Chlorpyrifos	8.5 floz/acre	7.12 gal	\$6.64	\$711.81
	Class Act NG	Ammonium sulfate, corn syrup, alkyl polyglycoside	2.5 gal/100gal	0 gal	\$0.00	\$0.00
	InterLock	Modified vegetable oil, polyoxyethylene sorbitan fatty acid ester, vegetable oil	4 floz/acre	3.35 gal	\$2.06	\$221.08
	Boomspray application		1 acre/acre	107.19 acre	\$8.00	\$857.52
					Total	\$2,312.96
Sugar Beets- Herbicide/ Insecticide- Round-Up PM, Class Act NG, Clorpyrifos 4E, Interlock 107.19 acre Oct 14, 2016 Broadcast	Water Rate		1,280 floz/acre	1,071.9 gal		
	Roundup PowerMAX Herbicide	Glyphosate as the Potassium Salt	32 floz/acre	26.8 gal	\$6.50	\$696.73
	Class Act NG	Ammonium sulfate, corn syrup, alkyl polyglycoside	16 floz/acre	13.4 gal	\$1.75	\$187.58
	Arysta Chlorpyrifos 4E AG	Chlorpyrifos	1.5 pt/acre	20.1 gal	\$11.44	\$1,225.99
	InterLock	Modified vegetable oil, polyoxyethylene sorbitan fatty acid ester, vegetable oil	4 floz/acre	3.35 gal	\$2.06	\$221.08
	Boomspray application		1 acre/acre	107.19 acre	\$8.00	\$857.52
					Total	\$3,188.90

SITUATION/ TIMING	INPUTS	ACTIVE	APPLY	UNITS	COST / ACRE	COST
Sugar Beets- Fungicide- Topaz, Micronized Sulfur, Masterlock 107.19 acre Oct 14, 2016 Aerial Spraying	Topaz	Propiconazole	4 floz/acre	3.35 gal	\$2.66	\$284.72
	UPI Microthiol Disperss	Sulfur	2 lbs/acre	214.38 lbs	\$7.46	\$799.64
	Masterlock	Modified vegetable oil, polyoxyethylene sorbitan fatty acid ester, vegetable oil, and soybean oil, ethoxylated	6 floz/acre	5.02 gal	\$1.27	\$135.66
	Spray/aerial		1 acre/acre	107.19 acre	\$10.00	\$1,071.90
					Total	\$2,291.92
Sugar Beet Harvest 107.19 acre Oct 14, 2016	Harvest		1 acre/acre	107.19 acre	\$50.00	\$5,359.50
					Total	\$5,359.50
Planting 107.19 acre Oct 14, 2016	Planting		1 acre/acre	107.19 acre	\$25.00	\$2,679.75
	BTS 20RR28		140 lbs/acre	15,006.6 lbs	\$70.00	\$7,503.30
					Total	\$10,183.05
					Total	\$0.00
					Total	\$23,336.33

HARVEST ACTIVITIES

SITUATION/TIMING	HARVESTED WEIGHT	PRICE	INCOME
Harvest 2016 107.19 acre Nov 15, 2017	4,494 ton	\$40.00 /ton	\$179,760.00
Total	4,494 ton	\$40.00 /ton	\$179,760.00

Springfield 5

FIELD SUMMARY

Costs	Income	Gross Profit	Gross Margin
\$105.11 /acre Total: \$7,335.33	\$391.17 /acre Total: \$27,300.00	\$286.07 /acre Total: \$19,964.67	73.13 %

INCOME SUMMARY

AREA	YIELD	PRICE	OTHER INCOME	TOTAL INCOME
69.79 acre	6.02 ton/acre	\$65.00 /ton	\$0.00	\$27,300.00

COST SUMMARY

SEED	FERTILIZER	CHEMICALS	CONTRACTORS	OPERATIONS	OTHER COSTS	TOTAL COST
\$0.00 /acre	\$73.54 /acre	\$15.56 /acre	\$0.00 /acre	\$16.00 /acre	\$0.00 /acre	\$105.11 /acre

ROTATION HISTORY

2016

Alfalfa

69.79 acre | LegenDairy XHD

Active Ingredients: N 8.6 lbs/acre Phosphate 4.58 lbs/acre K2O 0.1 lbs/acre Potash 2.74 lbs/acre Zn 0.04 lbs/acre
Organic acids including Humic and Fulvic 1.52 lbs/acre

ACTIVITIES

SITUATION/ TIMING	INPUTS	ACTIVE	APPLY	UNITS	COST / ACRE	COST
Alfalfa- Herbicide- Round-Up PM, Class Act, Interlock 69.79 acre Oct 14, 2016 Boomspray	Water Rate		1,280 floz/acre	697.9 gal		
	Roundup PowerMAX Herbicide	Glyphosate as the Potassium Salt	32 floz/acre	17.45 gal	\$6.50	\$453.64
	Class Act NG	Ammonium sulfate, corn syrup, alkyl polyglycoside	5 gal/100gal	34.9 gal	\$7.00	\$488.53
	InterLock	Modified vegetable oil, polyoxyethylene sorbitan fatty acid ester, vegetable oil	4 floz/acre	2.18 gal	\$2.06	\$143.94
	Boomspray application		1 acre/acre	69.79 acre	\$8.00	\$558.32
					Total	\$1,644.43
Alfalfa Foliar 69.79 acre Oct 14, 2016 Boomspray	Actagro Structure 7-21-0	Organic acids including Humic and Fulvic, Nitrogen, Phosphate, and Zinc	2 gal/acre	139.58 gal	\$16.00	\$1,116.64
	Valley Agronomics 32-0-0	Nitrogen	2 gal/acre	139.58 gal	\$5.01	\$349.35
	Actagro Katalyst 0-0-25	Potash	1 gal/acre	69.79 gal	\$15.00	\$1,046.85
	Actagro Liquid Humus 0-0-4	Potash	1 qt/acre	17.45 gal	\$37.54	\$2,619.74
	Boomspray application		1 acre/acre	69.79 acre	\$8.00	\$558.32
					Total	\$5,690.90
					Total	\$0.00
					Total	\$7,335.33

HARVEST ACTIVITIES

SITUATION/TIMING	HARVESTED WEIGHT	PRICE	INCOME
Harvest 2016			
69.79 acre	420 ton	\$65.00 /ton	\$27,300.00
Nov 15, 2017			
Total	420 ton	\$65.00 /ton	\$27,300.00

Springfield 6

FIELD SUMMARY

Costs	Income	Gross Profit	Gross Margin
\$105.11 /acre Total: \$4,814.89	\$353.63 /acre Total: \$16,200.00	\$248.53 /acre Total: \$11,385.11	70.28 %

INCOME SUMMARY

AREA	YIELD	PRICE	OTHER INCOME	TOTAL INCOME
45.81 acre	5.89 ton/acre	\$60.00 /ton	\$0.00	\$16,200.00

COST SUMMARY

SEED	FERTILIZER	CHEMICALS	CONTRACTORS	OPERATIONS	OTHER COSTS	TOTAL COST
\$0.00 /acre	\$73.54 /acre	\$15.56 /acre	\$0.00 /acre	\$16.00 /acre	\$0.00 /acre	\$105.11 /acre

ROTATION HISTORY

2016

Alfalfa

45.81 acre | LegenDairy XHD

Active Ingredients: N 8.6 lbs/acre Phosphate 4.58 lbs/acre K2O 0.1 lbs/acre Potash 2.74 lbs/acre Zn 0.04 lbs/acre
Organic acids including Humic and Fulvic 1.52 lbs/acre

ACTIVITIES

SITUATION/ TIMING	INPUTS	ACTIVE	APPLY	UNITS	COST / ACRE	COST
Alfalfa- Herbicide- Round-Up PM, Class Act, Interlock 45.81 acre Oct 14, 2016 Boomspray	Water Rate		1,280 floz/acre	458.1 gal		
	Roundup PowerMAX Herbicide	Glyphosate as the Potassium Salt	32 floz/acre	11.45 gal	\$6.50	\$297.77
	Class Act NG	Ammonium sulfate, corn syrup, alkyl polyglycoside	5 gal/100gal	22.91 gal	\$7.00	\$320.67
	InterLock	Modified vegetable oil, polyoxyethylene sorbitan fatty acid ester, vegetable oil	4 floz/acre	1.43 gal	\$2.06	\$94.48
	Boomspray application		1 acre/acre	45.81 acre	\$8.00	\$366.48
					Total \$1,079.40	
Alfalfa Foliar 45.81 acre Oct 14, 2016 Boomspray	Actagro Structure 7-21-0	Organic acids including Humic and Fulvic, Nitrogen, Phosphate, and Zinc	2 gal/acre	91.62 gal	\$16.00	\$732.96
	Valley Agronomics 32-0-0	Nitrogen	2 gal/acre	91.62 gal	\$5.01	\$229.31
	Actagro Katalyst 0-0-25	Potash	1 gal/acre	45.81 gal	\$15.00	\$687.15
	Actagro Liquid Humus 0-0-4	Potash	1 qt/acre	11.45 gal	\$37.54	\$1,719.59
	Boomspray application		1 acre/acre	45.81 acre	\$8.00	\$366.48
					Total \$3,735.50	
					Total \$0.00	
					Total \$4,814.89	

HARVEST ACTIVITIES

SITUATION/TIMING	HARVESTED WEIGHT	PRICE	INCOME
Harvest 2016			
45.81 acre	270 ton	\$60.00 /ton	\$16,200.00
Nov 15, 2017			
Total	270 ton	\$60.00 /ton	\$16,200.00

Notes:

¹ These seasons contain aggregate values because the field was split/grouped.:

² All costs per acre are divided by the area of the field. All yields are calculated based on the area of the field in this season.